

TE...B

TE...B

# TE...B

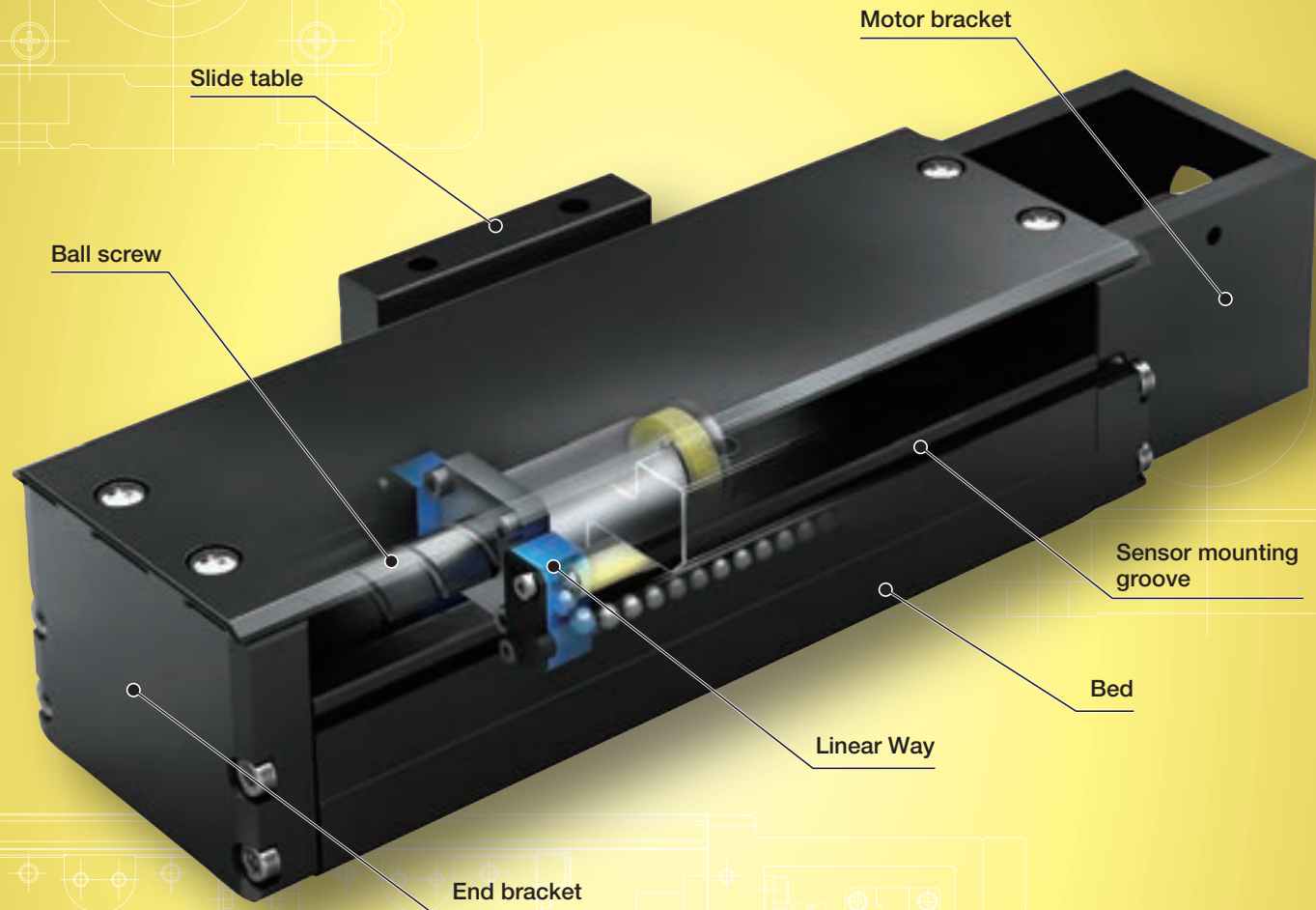
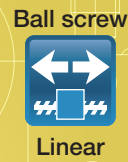

## Major product specifications

Driving method	Precision ball screw
Linear motion rolling guide	Linear Way (ball type)
Built-in lubrication part	Lubrication part "C-Lube" is built-in
Material of table and bed	High-strength aluminum alloy
Sensor	Select by identification number

## Accuracy

Positioning repeatability	±0.002~0.020
Positioning accuracy	0.035~0.065
Lost motion	-
Parallelism in table motion A	-
Parallelism in table motion B	0.008~0.016
Attitude accuracy	-
Straightness	-
Backlash	0.005

unit: mm

# Points

## 1 Light weight, low profile and high-precision positioning table

Light weight, low profile and compact positioning table using high-strength aluminum alloy for its main components with a slide table assembled inside a U-shaped bed. The mass of the entire table is reduced to about 40% of TU series. Low cross sectional height (26mm for TE50B, 33mm for TE60B, and 46mm for TE86B). Moreover, the structure of various sensors directly installable on sensor mounting groove of the bed contributes to the miniaturization.

## 2 Table specification is selectable according to your use

There are two types in the shape of slide table: standard and with flange. The number of slide tables, motor folding back specification, ball screw lead, with or without a dust protection cover, installation of various sensors can be selected, you can select an optimal product for the specifications of your machine and device.

## 3 Excellent cost performance

The excellent cost performance is realized by reducing the number of parts, and optimizing the part shapes.

## Comparison with Precision Positioning Table TU

### Sectional height

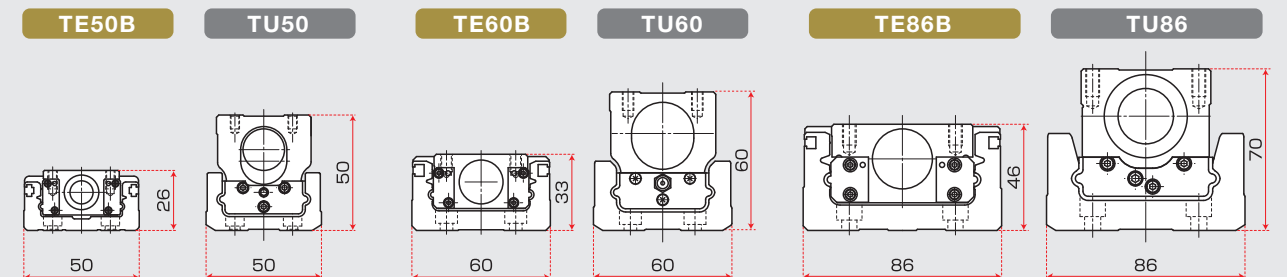

### Mass

Model and size	Stroke length (mm)	Overall length (mm)	Mass (kg)	Mass / 100mm (kg)
TE50B	60	218	0.52	0.24
TU50	60	226	1.8	0.80
TE60B	100	269	1.0	0.37
TU60	100	298	3.3	1.11
TE86B	300	523	3.7	0.71
TU86	250	498	10.9	2.19

## Variation

Shape	Model	Bed width (mm)		
		50	60	86
Standard	TE...BS	☆	☆	☆
With flange	TE...BF	☆	☆	☆

1N=0.102kgf=0.2248lbs.  
1mm=0.03937inch

# Identification Number

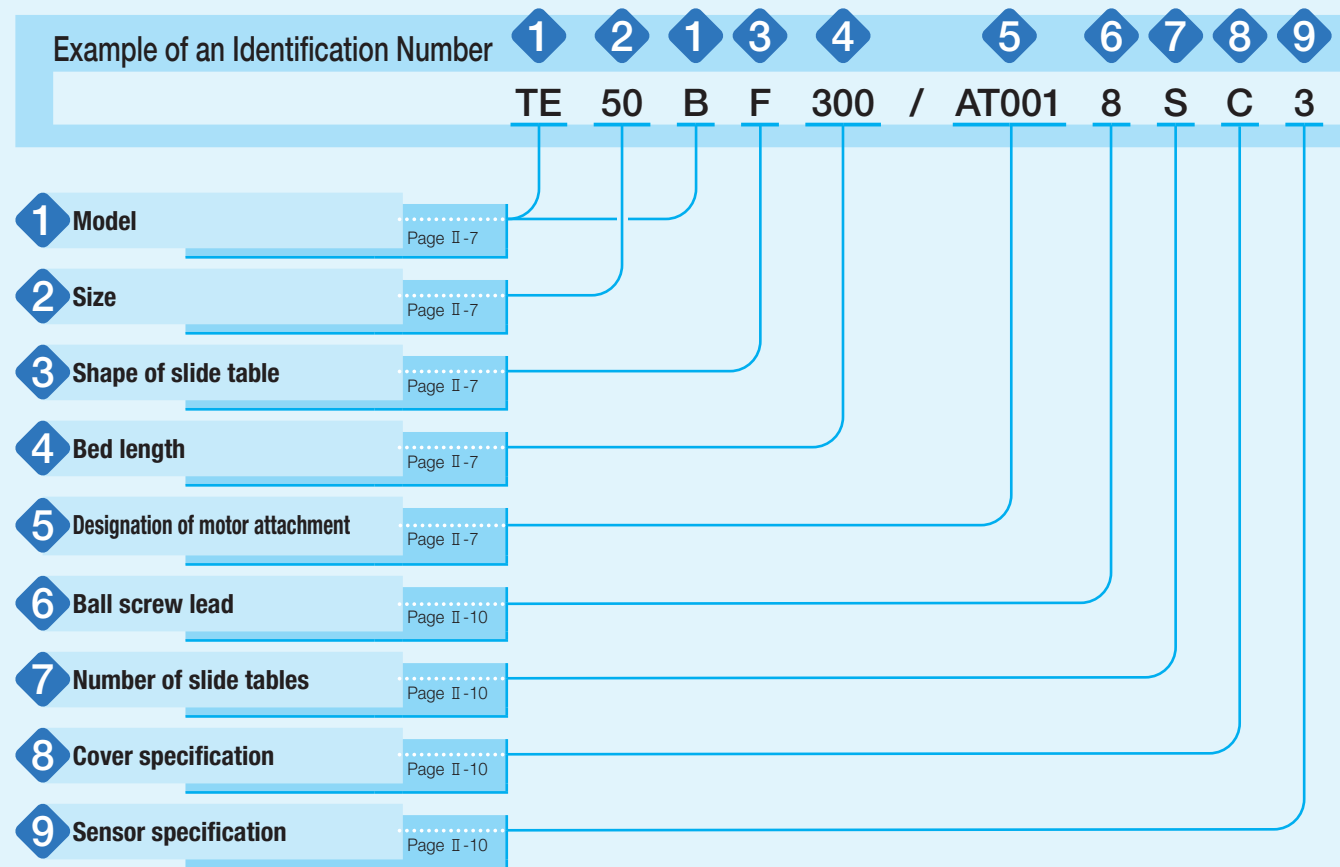

# Identification Number and Specification

<b>1 Model</b>	TE··B: Precision Positioning Table TE
<b>2 Size</b>	Size indicates bed width. Select a size from the list of Table 1.
<b>3 Shape of slide table</b>	S: Standard table F: Flange type standard table
<b>4 Bed length</b>	Select a bed length from the list of Table 1.

**Table 1 Sizes and bed lengths** unit: mm

Model and size	Bed width	Bed length
TE50B	50	150, 200, 250, 300, 400, 500
TE60B	60	150, 200, 300, 400, 500, 600, 700
TE86B	86	340, 440, 540, 640, 740, 840, 940

Remark: For stroke length, please see the dimension tables shown in pages of II-19 or later.

<b>5 Designation of motor attachment</b>	AT000 : Motor inline specification	Without motor attachment
	AT001 to AT011 : Motor inline specification	With motor attachment
	AR000 : Motor folding back specification	Without motor attachment
	AR001 to AR008 : Motor folding back specification	With motor attachment
To specify the motor attachment, select it from the list of Table 2.1 and Table 2.2.		
<ul style="list-style-type: none"> <li>Please specify motor folding back specification and motor attachment applicable to motor for use.</li> <li>If motor inline specification with motor attachment is specified, the main body is shipped with a coupling indicated in the Table 3 mounted. However, the final position adjustment should be made by customer since it is only temporarily fixed. For a product without motor attachment (AT000), no coupling is attached.</li> <li>If motor folding back specification with motor attachment is specified, "housing applicable to the specified motor, pulley (on motor side and ball screw side), cover, motor bracket, belt and bolts necessary for assembly" are supplied. Motor mounting bolts should be prepared by customer.</li> </ul>		

# Identification Number and Specification

**Table 2.1 Application of motor attachment (motor inline specification)**

Type	Motor to be used				Flange size mm	Motor attachment		
	Manufacturer	Series	Model	Rated output W		TE50B	TE60B	TE86B
AC servo motor	YASKAWA ELECTRIC CORPORATION	Σ-7	SGM7J-A5A	50	□40	AT001	AT002	—
			SGM7A-A5A			AT001	AT002	—
			SGM7J-01A	100		—	AT002	—
			SGM7A-01A			—	AT002	—
			SGM7J-02A	200		—	—	AT003
			SGM7A-02A			—	—	AT003
	Mitsubishi Electric Corporation	J4/J5	HG-MR053	50	□40	AT001	AT002	—
			HG-KR053/HK-KT053W			AT001	AT002	—
			HG-MR13	100		—	AT002	—
			HG-KR13/HK-KT13W			—	AT002	—
			HG-MR23	200		—	—	AT003
			HG-KR23/HK-KT23W			—	—	AT003
	Panasonic Corporation	MINAS A6	MSMF5A	50	□38	AT004	AT005	—
			MSMF01	100		—	AT005	—
MSMF02			200	—		—	AT006	
Hitachi Industrial Equipment Systems Co., Ltd	AD	ADMA-R5L	50	□40	AT001	AT002	—	
		ADMA-01L	100		—	AT002	—	
		ADMA-02L	200		—	—	AT003	
Stepper motor	ORIENTAL MOTOR Co., Ltd.	α step	ARM46	□42	AT007	—	—	
			ARM66		—	—	AT008	
			ARM69		—	—	AT008	
		CRK	CRK54	□42	AT009	—	—	
			CRK56 (1)	□60	—	AT010	AT011	

Note (1) Applicable to the outer diameter φ8 of motor output shaft.

Remark: For detailed motor specifications, please see respective motor manufacturer's catalog.

**Table 2.2 Application of NEMA motor attachment (motor inline specification)**

Type	Motor to be used				Flange size inch	Motor attachment		
	Manufacturer	Series	Model	Rated output W		TE50B	TE60B	TE86B
AC servo motor		TLY(metric)	TLY-A110(AA type)	41	□40	AT001	AT002	—
			TLY-A120(AA type)	86	□40	AT001	AT002	—
			TLY-A130(AA type)	140	□40	AT001	AT002	—
			TLY-A220(AA type)	350	□60	—	—	AT003 (2)
			TLY-A230(AA type)	440	□60	—	—	AT003 (2)
		TLY(NEMA)	TLY-A120(AN type)	86	□42	TAE9043-ATE137 (1)	—	—
			TLY-A130(AN type)	140	□42	TAE9043-ATE137 (1)	—	—
			TLY-A220(AN type)	350	□56.4	—	—	TAE9017-ATE135 (1)
			TLY-A230(AN type)	440	□56.4	—	—	TAE9017-ATE135 (1)
			TLY-A2530(AN type)	690	□86	—	—	TAE9056-ATE134 (1)
			TLY-A2540(AN type)	860	□86	—	—	TAE9056-ATE134 (1)
Servo or Stepper	NEMA17C				TAE9043-ATE110 (1)(2)	—	—	
	NEMA23D				TAE9017-ATE096 (1)	TAE9017-ATE096 (1)(2)	—	
					TAE9017-ATE097 (1)(2)	TAE9017-ATE097 (1)(2)	—	
NEMA34D				—	—	TAE9056-ATE095 (1)(2)		

Note (1) The TAE part numbers are the part number of motor attachment component sold separately. In the TE part number, please choose motor attachment code AT000. No Coupling is included. It is required to consider customer's operation patterns for these motor attachment.

(2) Please confirm the length and the diameter of the motor shaft etc., and check the usability of the motor attachment with your motor beforehand.

(3) It is required to change the delivered coupling to XGS-30C-8×12 which is for the 12mm motor shaft by customer.

Remark: For detailed motor specifications, please see respective motor manufacturer's catalog.

Table 2.3 Application of motor attachment (motor folding back specification)

Type	Motor to be used				Flange size mm	Motor attachment		
	Manufacturer	Series	Model	Rated output W		TE50B	TE60B	TE86B
AC servo motor	YASKAWA ELECTRIC CORPORATION	Σ-7	SGM7J-A5A	50	□40	AR001	AR002	—
			SGM7A-A5A			AR001	AR002	—
			SGM7J-01A	100		—	AR002	—
			SGM7A-01A			—	AR002	—
			SGM7J-02A	200		—	—	AR003
			SGM7A-02A			—	—	AR003
	Mitsubishi Electric Corporation	J4/J5	HG-MR053	50	□40	AR001	AR002	—
			HG-KR053/HK-KT053W			AR001	AR002	—
			HG-MR13	100		—	AR002	—
			HG-KR13/HK-KT13W			—	AR002	—
			HG-MR23	200		—	—	AR003
	HG-KR23/HK-KT23W	—	—		AR003			
	Panasonic Corporation	MINAS A6	MSMF5A	50	□38	AR004	AR005	—
			MSMF01	100		—	AR005	—
			MSMF02	200		—	—	AR006
	Hitachi Industrial Equipment Systems Co., Ltd	AD	ADMA-R5L	50	□40	AR001	AR002	—
ADMA-01L			100	—		AR002	—	
ADMA-02L			200	—		—	AR003	
Stepper motor	ORIENTAL MOTOR Co., Ltd.	α step	ARM46		□42	AR007	—	—
		CRK	CRK54			AR008	—	—

Remark: For detailed motor specifications, please see respective motor manufacturer's catalog.

Table 3 Coupling models (motor inline specification)

Motor attachment	Coupling models	Manufacturer	Coupling inertia $J_c$ $\times 10^{-8} \text{kg} \cdot \text{m}^2$
AT001	XGS-19C- 5× 8	Nabeya Bi-tech Kaisha	0.062
AT002	XGS-19C- 5× 8	Nabeya Bi-tech Kaisha	0.062
AT003	XGS-30C- 8×14	Nabeya Bi-tech Kaisha	0.55
AT004	XGS-19C- 5× 8	Nabeya Bi-tech Kaisha	0.062
AT005	XGS-19C- 5× 8	Nabeya Bi-tech Kaisha	0.062
AT006	XGS-30C- 8×11	Nabeya Bi-tech Kaisha	0.55
AT007	XGS-19C- 5× 6	Nabeya Bi-tech Kaisha	0.062
AT008	XGS-30C- 8×10	Nabeya Bi-tech Kaisha	0.55
AT009	XGS-19C- 5× 5	Nabeya Bi-tech Kaisha	0.062
AT010	XGS-19C- 5× 8	Nabeya Bi-tech Kaisha	0.062
AT011	XGS-30C- 8× 8	Nabeya Bi-tech Kaisha	0.55
TAE9043-ATE137	XGS-19C- 5× 6.35	Nabeya Bi-tech Kaisha	0.062
TAE9017-ATE135	XGS-30C- 8×12.7	Nabeya Bi-tech Kaisha	0.55
TAE9056-ATE134	XGS-34C- 8×15.875	Nabeya Bi-tech Kaisha	1.0

Remark: For detailed coupling specification, please see the manufacturer's catalog.

6 Ball screw lead

Select from among ball screw leads applicable to the sizes and bed lengths shown in the table below.

Model and size	Bed length mm	Ball screw lead mm				
		4	5	8	10	20
TE50B	300 or less	○	—	○	—	—
	400 or more	—	—	○	—	—
TE60B	600 or less	—	○	—	○	—
	700	—	—	—	—	○
TE86B	All	—	—	—	○	○

7 Number of slide table

S: One unit  
C: Two units

8 Cover specification

0: Without cover  
C: With bridge cover (applied to TE...BF)

9 Specification of sensor

0: Without sensor  
2: Two units of sensor mounted (limit)  
3: Three units of sensor mounted (limit, pre-origin)  
4: Four units of sensor mounted (limit, pre-origin, origin)  
5: Two sensors attached (limit)  
6: Three sensors attached (limit, pre-origin)  
7: Four sensors attached (limit, pre-origin and origin sensors)

If sensor mounting (symbol 2, 3, or 4) is specified, the sensor is mounted into the mounting groove on the side of bed, and two detecting plates are attached onto the slide table.  
If sensor attachment (symbol 5, 6, or 7) is specified, specified number of sensors are attached including mounting screws for sensors, nuts, two detecting plates, and mounting screws for the detecting plates.



# Specifications

**Table 4 Accuracy**

unit: mm

Model and size	Bed length	Positioning repeatability	Positioning accuracy (1)	Parallelism in table motion B	Backlash (1)
TE50B	150	±0.002 (±0.020)	0.035	0.008	0.005
	200		0.040		
	250				
	300				
	400		0.045	0.010	
500	0.012				
TE60B	150	±0.002 (±0.020)	0.035	0.008	0.005
	200		0.040		
	300				
	400				
	500		0.045	0.010	
	600		0.012		
700	0.060	0.012			
TE86B	340	±0.002 (±0.020)	0.040	0.008	0.005
	440		0.045	0.010	
	540		0.050	0.012	
	640				
	740		0.055	0.014	
	840		0.065	0.016	
	940				

Note (1) This does not apply to table of motor folding back specification.

Remark: The values in ( ) are reference values provided that the timing belt tension is properly adjusted in motor folding back specification table.

**Table 5 Maximum carrying mass**

Model and size	Ball screw lead mm	Carrying mass position mm	Maximum carrying mass kg									
			Height H	Length L	Horizontal direction				Vertical direction			
					0	100	200	300	0	100	200	300
TE50B	4	0	12	12	7	5	11	7	3.8	2.6		
		100	12	12	7	4.9	6	4.4	2.9	2.1		
		200	12	11	6	4.7	3.6	2.8	2.3	1.8		
	8	0	12	10	6	4.6	2.5	2.1	1.8	1.6		
		100	12	10	5	3.9	7	5	2.9	2.0		
		200	12	8	5	3.6	5	3.4	2.3	1.7		
TE60B	5	0	17	17	11	8	13	10	5	3.8		
		100	17	17	11	7	9	6	4.4	3.2		
		200	17	16	10	7	5	4.2	3.5	2.8		
	10	0	17	14	9	7	3.7	3.1	2.7	2.4		
		100	17	15	8	5	8	8	4.3	3.0		
		200	17	11	7	5	7	5	3.4	2.5		
	20	0	17	9	6	4.8	4.1	3.3	2.7	2.1		
		100	13	8	5	4.4	2.8	2.4	2.1	1.8		
		200	17	9	5	3.8	7	5	3.2	2.2		
	TE86B	10	0	36	36	25	18	18	18	13	9	
			100	36	35	22	16	18	15	10	7	
			200	36	29	20	15	12	10	8	6	
20		0	36	24	17	13	9	7	6	5		
		100	29	28	16	11	10	10	10	6		
		200	29	19	13	10	10	10	7	5		
300		23	15	11	8	9	7	6	5			
300		17	12	9	7	6	5	4.8	4.3			

Remarks 1. The value is for one flange type standard table.

2. The maximum carrying mass is adjusted by the mass when the rating life of the linear motion rolling guide, ball screws, or bearings is 18,000 hours during continuous operation at a number of revolutions of the motor of 3000min<sup>-1</sup> and an acceleration/deceleration time of 0.2s. The mass calculated is based upon the basic static load rating of the linear motion rolling guide.

**Table 6 Maximum load mass**

Model and size	Ball screw lead mm	Maximum load mass kg	
		Horizontal direction	Vertical direction
TE50B	4	105	26
	8	55	13
TE60B	5	172	44
	10	90	22
TE86B	10	46	11
	20	175	45
	20	91	23

Remarks 1. The maximum load mass shows the mass that ensures acceleration/deceleration of 0.3G.

2. The values shown in this table were calculated with the motor with the highest rated torque installed, selected from the AC servomotor models listed in Table 2.1.

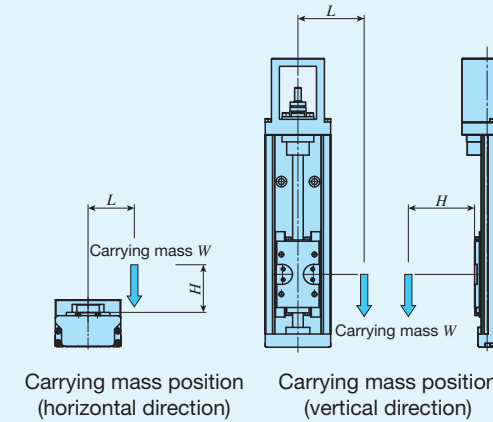

**Table 7 Allowable moment**

Model and size	Allowable moment (1) N · m		
	T <sub>0</sub>	T <sub>x</sub>	T <sub>y</sub>
TE50B	9.8 (19.6)	9.8 ( 48.4)	9.8 ( 48.4)
TE60B	16.7 (33.4)	16.7 ( 88.1)	16.7 ( 88.1)
TE86B	49.0 (98.0)	49.0 (247.0)	49.0 (247.0)

Note (1) The value in ( ) represents two slide tables in close contact.

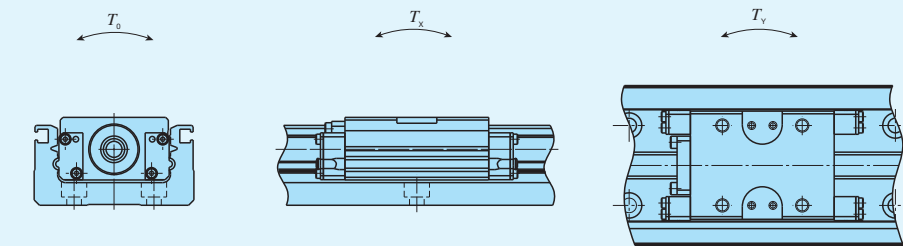

## ■ Allowable moment

Allowable moment refers to the maximum static moment that can be used without affecting functions or performance. Therefore, do not exceed the allowable moment value during operation.

## Specifications

**Table 8 Load rating of linear motion rolling guide**

Model and size	Basic dynamic load rating $C$ N	Basic static load rating $C_0$ N	Static moment rating <sup>(1)</sup> N · m		
			$T_0$	$T_x$	$T_y$
TE50B	8 490	12 500	211 ( 422)	99.5 ( 508)	99.5 ( 508)
TE60B	12 400	17 100	354 ( 708)	151 ( 795)	151 ( 795)
TE86B	26 800	35 900	1 110 (2 220)	472 (2 400)	472 (2 400)

Note <sup>(1)</sup> In directions indicated in the above figures, the value in ( ) is for two slide tables in close contact.

**Table 9 Maximum speed**

Motor type	Model and size	Bed length mm	Maximum speed mm/s				
			Lead 4mm	Lead 5mm	Lead 8mm	Lead 10mm	Lead 20mm
AC servomotor	TE50B	300 or less	400	—	800	—	—
		400	—	—	800	—	—
		500	—	—	620	—	—
	TE60B	500 or less	—	500	—	1 000	—
		600	—	350	—	710	—
		700	—	—	—	—	960
	TE86B	540 or less	—	—	—	930	1 860
		640	—	—	—	830	1 630
		740	—	—	—	590	1 170
		840	—	—	—	440	880
		940	—	—	—	340	690
	Stepper motor	TE50B	300 or less	120	—	240	—
400			—	—	240	—	—
500			—	—	240	—	—
TE60B		600 or less	—	150	—	300	—
		700	—	—	—	—	600
TE86B		940 or less	—	—	—	300	600

Remark: To measure the practical maximum speed, it is required to consider operation patterns based on the motor to be used and load conditions.

**Table 10.1 Specifications of ball screw 1**

Model and size	Lead mm	Shaft dia. mm	Basic dynamic load rating $C$	Basic static load rating $C_0$
			N	N
TE50B	4	8	2 290	3 575
	8		1 450	2 155
TE60B	5	10	2 730	4 410
	20		1 720	2 745
TE86B	10	12	3 820	6 480
	20		2 300	3 920

**Table 10.2 Specifications of ball screw 2**

unit: mm

Model and size	Bed length	Shaft dia.	Overall length
TE50B	150	8	192.5
	200		242.5
	250		292.5
	300		342.5
	400		442.5
TE60B	500	10	542.5
	150		194
	200		244
	300		344
	400		444
TE86B	500	12	544
	600		644
	700		744
	340		395
	440		495
	540		595
	640		695
	740		795
	840		895
	940		995

**Table 11 Moment of inertia of sectional area of bed**

Model and size	Moment of inertia of sectional area mm <sup>4</sup>		Center of gravity $e$ mm
	$I_x$	$I_y$	
TE50B	$1.3 \times 10^4$	$1.2 \times 10^5$	6.4
TE60B	$4.7 \times 10^4$	$3.2 \times 10^5$	8.8
TE86B	$2.0 \times 10^5$	$1.3 \times 10^6$	13.0

Table 12 Table inertia and starting torque

Model and size	Bed length mm	Table inertia $J_T$ <sup>(2)</sup> $\times 10^{-5} \text{kg} \cdot \text{m}^2$										Starting torque $T_s$ <sup>(1)</sup> N · m
		Standard table					Flange type standard table					
		Lead					Lead					
		4mm	5mm	8mm	10mm	20mm	4mm	5mm	8mm	10mm	20mm	
TE50B	150	0.057	—	0.071	—	—	0.060	—	0.084	—	—	0.03
	200	0.069	—	0.083	—	—	0.072	—	0.096	—	—	
	250	0.085	—	0.099	—	—	0.088	—	0.112	—	—	
	300	0.097	—	0.111	—	—	0.100	—	0.124	—	—	
	400	—	—	0.139	—	—	—	—	0.152	—	—	
TE60B	500	—	—	0.167	—	—	—	—	0.180	—	—	0.03
	150	—	0.13	—	0.17	—	—	0.14	—	0.20	—	
	200	—	0.19	—	0.23	—	—	0.20	—	0.26	—	
	300	—	0.26	—	0.30	—	—	0.27	—	0.33	—	
	400	—	0.33	—	0.36	—	—	0.34	—	0.40	—	
	500	—	0.40	—	0.44	—	—	0.41	—	0.47	—	
	600	—	0.47	—	0.51	—	—	0.48	—	0.54	—	
TE86B	700	—	—	—	—	0.76	—	—	—	—	0.88	0.05
	340	—	—	—	0.73	1.19	—	—	—	0.81	1.50	
	440	—	—	—	0.88	1.35	—	—	—	0.95	1.64	
	540	—	—	—	1.03	1.50	—	—	—	1.11	1.80	
	640	—	—	—	1.18	1.64	—	—	—	1.25	1.95	
	740	—	—	—	1.33	1.79	—	—	—	1.41	2.10	
	840	—	—	—	1.48	1.94	—	—	—	1.56	2.25	
940	—	—	—	1.63	2.10	—	—	—	1.71	2.40		

Notes <sup>(1)</sup> When two units of slide table are used, it is about 1.5 times as long as that of one unit, and when table of motor folding back specification is used, it is about twice.

<sup>(2)</sup> For motor folding back specification, please add the following value to the value in the table.  
TE50B:  $0.17 \times 10^{-5} \text{kg} \cdot \text{m}^2$ , TE60B:  $0.39 \times 10^{-5} \text{kg} \cdot \text{m}^2$ , TE86B:  $0.86 \times 10^{-5} \text{kg} \cdot \text{m}^2$

## Mounting

For the processing accuracy of the Precision Positioning Table mounting surface and the tightening torque of the fixing screws, see page III-30.

## Motor Folding Back Specification

Motor folding back specification is available for Precision Positioning Table TE, space can be saved by folding back the motor and reducing the overall length of the table. For dimensions of motor folding back specification, please refer to respective dimension table.

For motor folding back specification, assembly should be made by customer since "housing applicable to the specified motor, pulley (on motor side and ball screw side), cover, motor bracket, belt and bolts necessary for assembly" are supplied. However, motor mounting bolts should be prepared by customer. The motor attachment can be attached in 4 directions as indicated in the following figure.

There is difference in dimension between where the motor attachment or the motor is lower than the bottom of the bed depending on the motor folding back direction. Do the design ensuring that the peripheral components do not interfere and that enough allowance is provided according to the approximate values in the dimension table shown in Page II-25 to II-30.

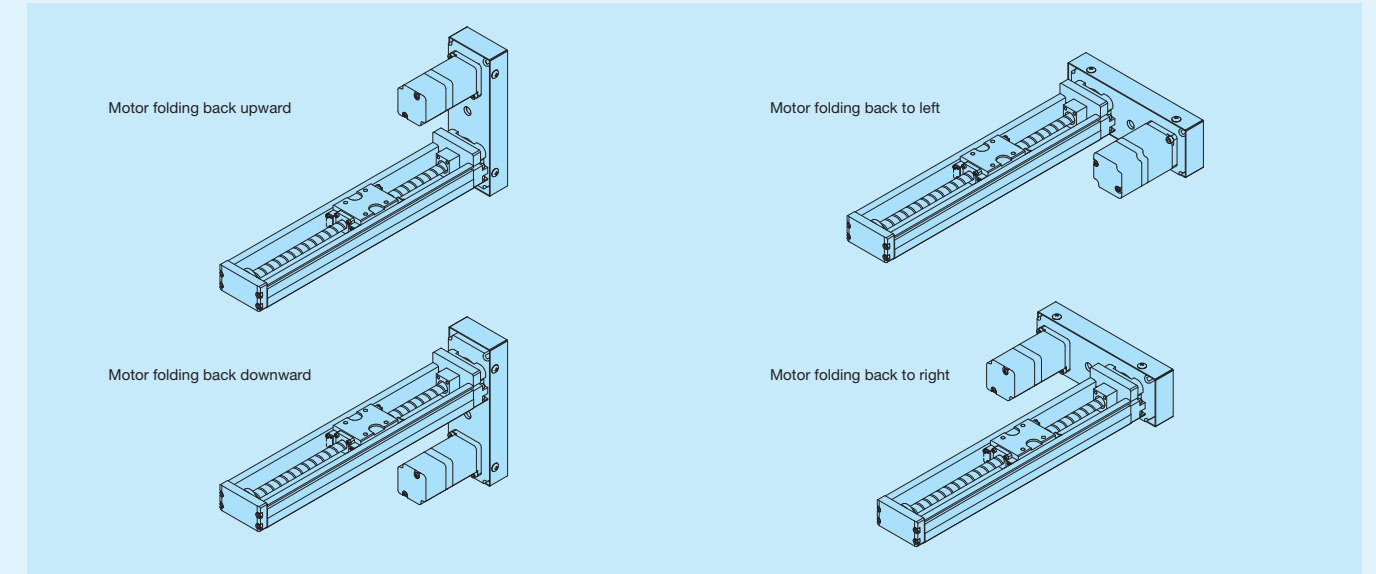

## Two Slide Table Specification

Two slide table specification is available for Precision Positioning Table TE. Ball screw nuts are mounted on slide table at the motor side, and it can be driven by the motor (driving table). Ball screw nuts are not mounted on slide table at the opposite motor side, and it is free condition (driven table).

It is possible to make the structure resistant to moment load by using two slide tables in combination (Table 7). When combining slide tables, allow more clearance than "Minimum center distance between two slide tables in close contact" described in the dimension table shown in pages II-19 to II-30. (Enlarging the span will shorten the stroke.)

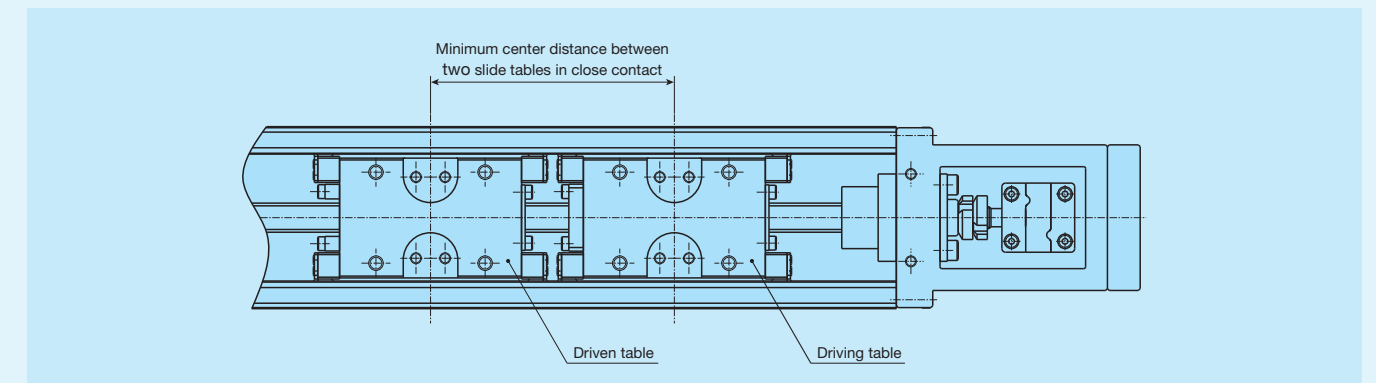
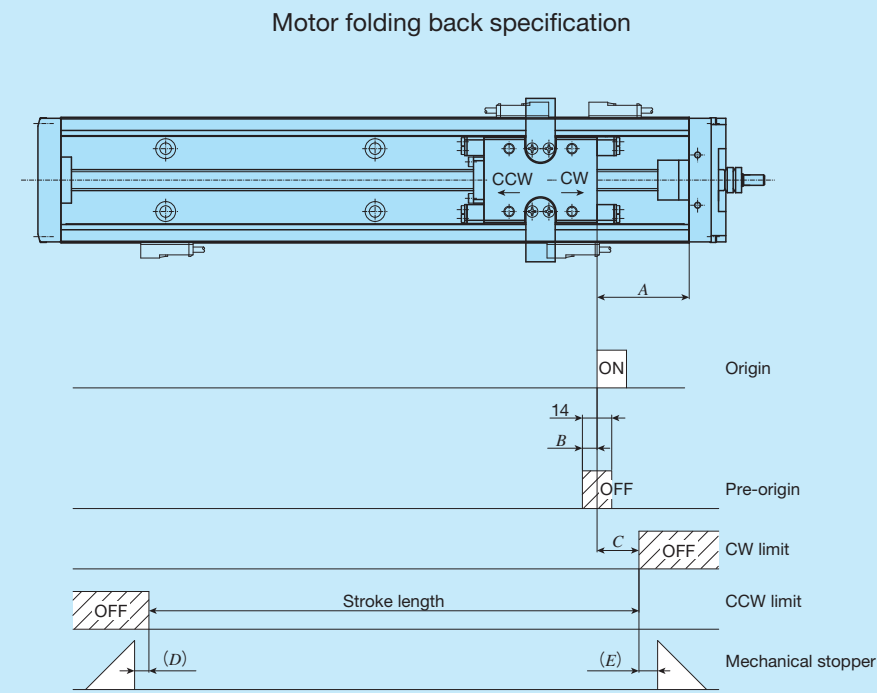
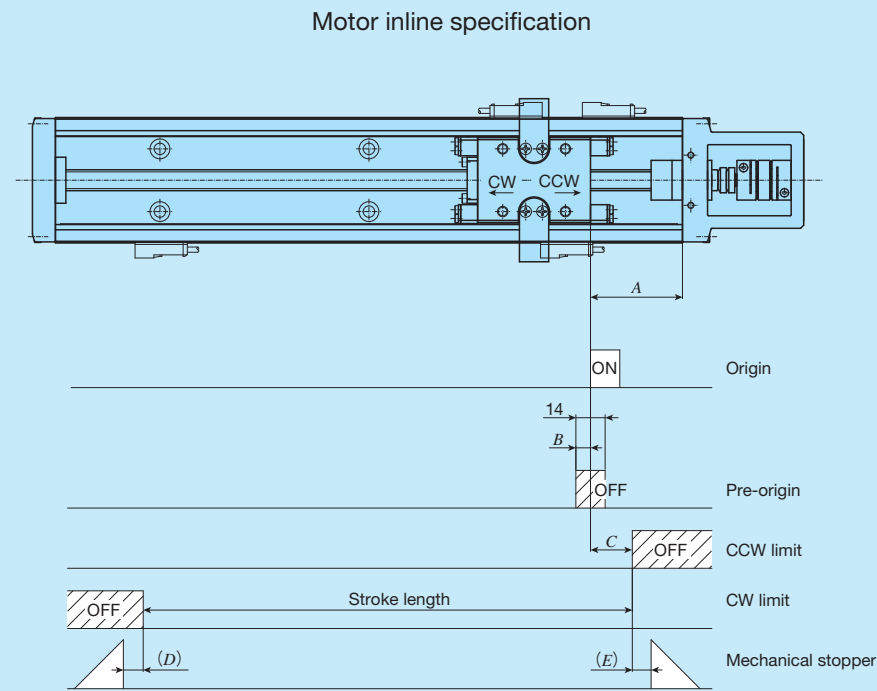

Table 13 Sensor timing chart



unit: mm

Model and size	Ball screw lead	A	B	C	D <sup>(1)</sup>	E
TE50B	4	33	2	10	6 ( 9 )	5
	8		6			
TE60B	5	44	3	20	9.5( 8.5)	9
	10		12			
TE86B	10	50	7	20	11 ( 11 )	10
	20		12			

Note (1) The value in ( ) represents dimensions for two slide tables.  
 Remarks 1. Mounting a sensor is specified using the corresponding identification number.  
 2. For the specifications of respective sensors, please see the section of sensor specification in General Explanation.  
 3. For the motor folding back specification, CW and CCW will invert.

## Motor inline specification

Remark: Motor attachment for NEMA, please see the pages III-32 or later.

### TE50B

AT000  
(without attachment)

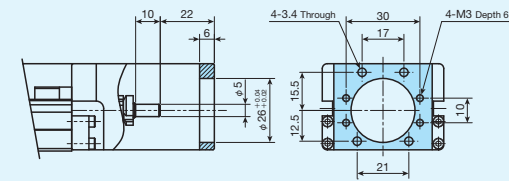

AT001

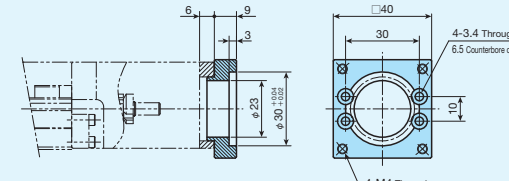

AT004

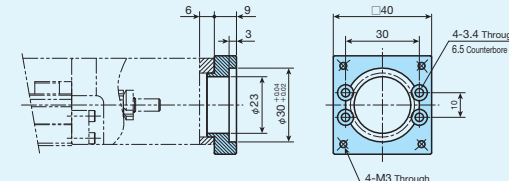

AT007  
AT009

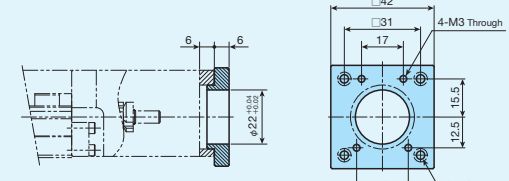

### TE60B

AT000  
(without attachment)

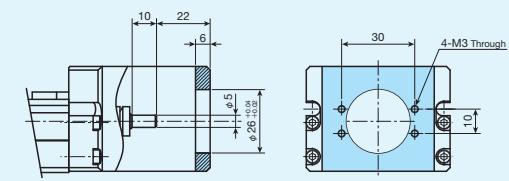

AT002

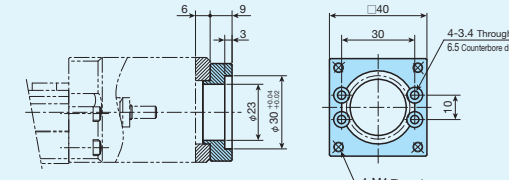

AT005

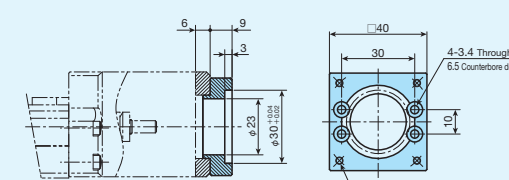

AT010

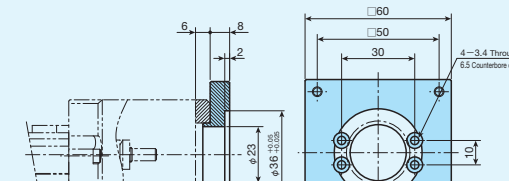

TAE9043-ATE110

TAE9043-ATE109

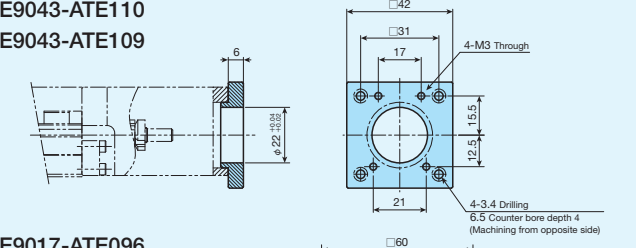

TAE9017-ATE096

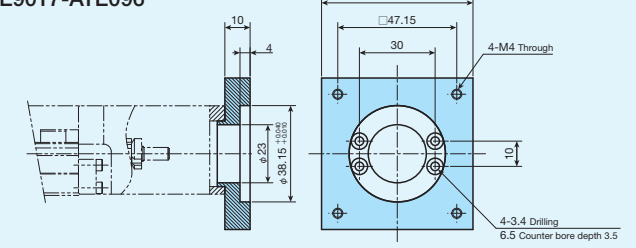

TAE9043-ATE137

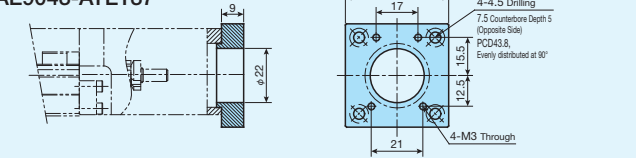

TAE9017-ATE096

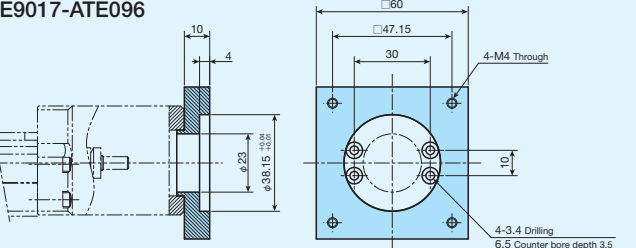

TAE9017-ATE097

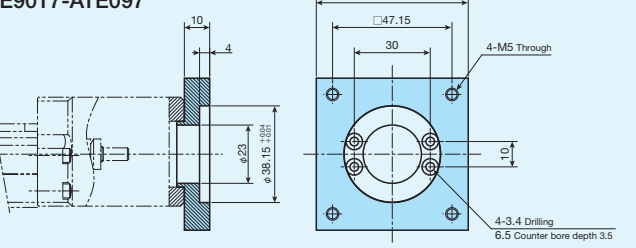



TE86B

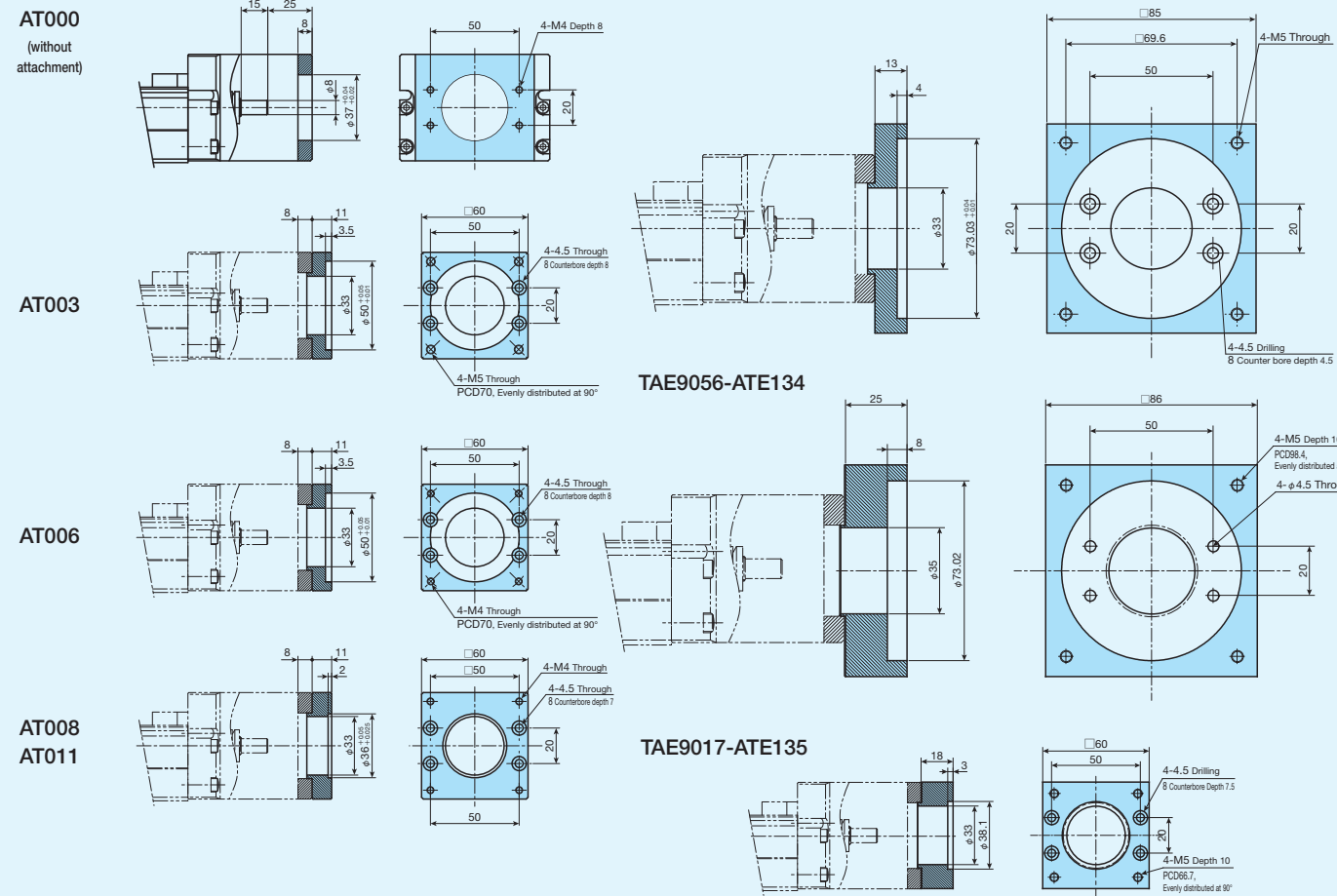

TE60B

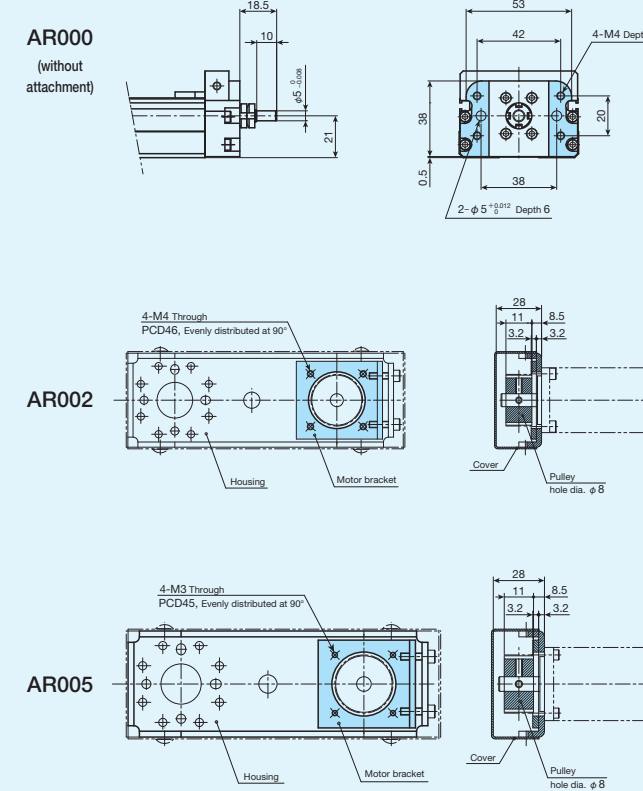

TE86B

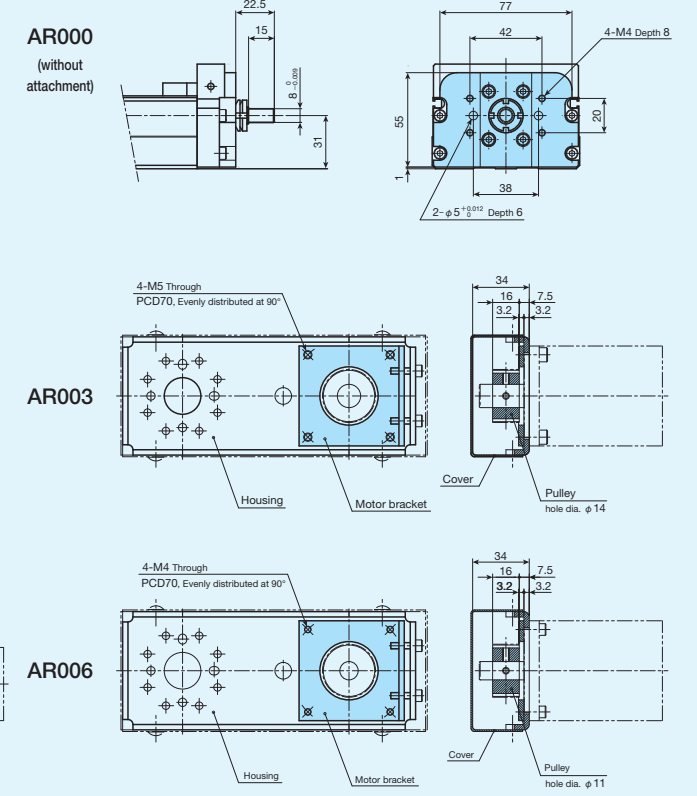

Motor folding back specification

TE50B

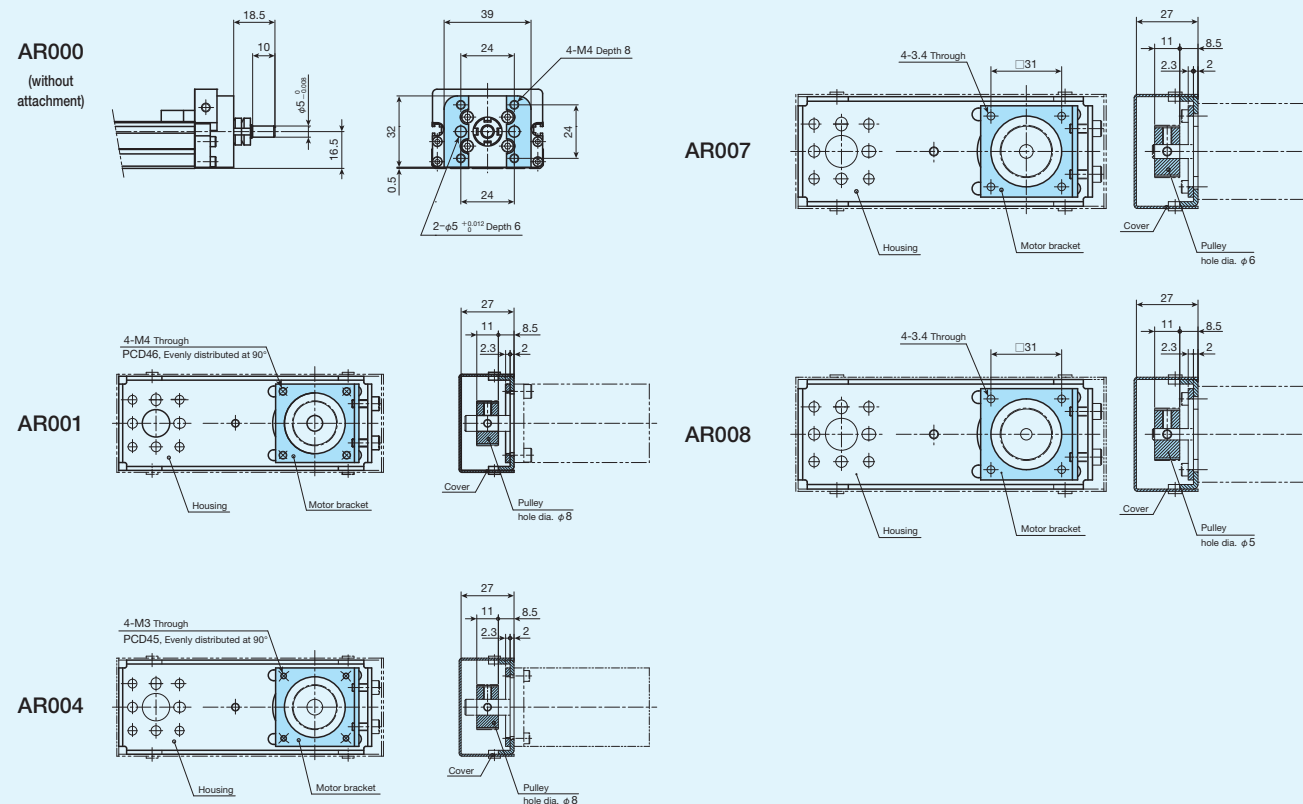

# IKO Precision Positioning Table TE

## TE50BS (Motor inline specification)

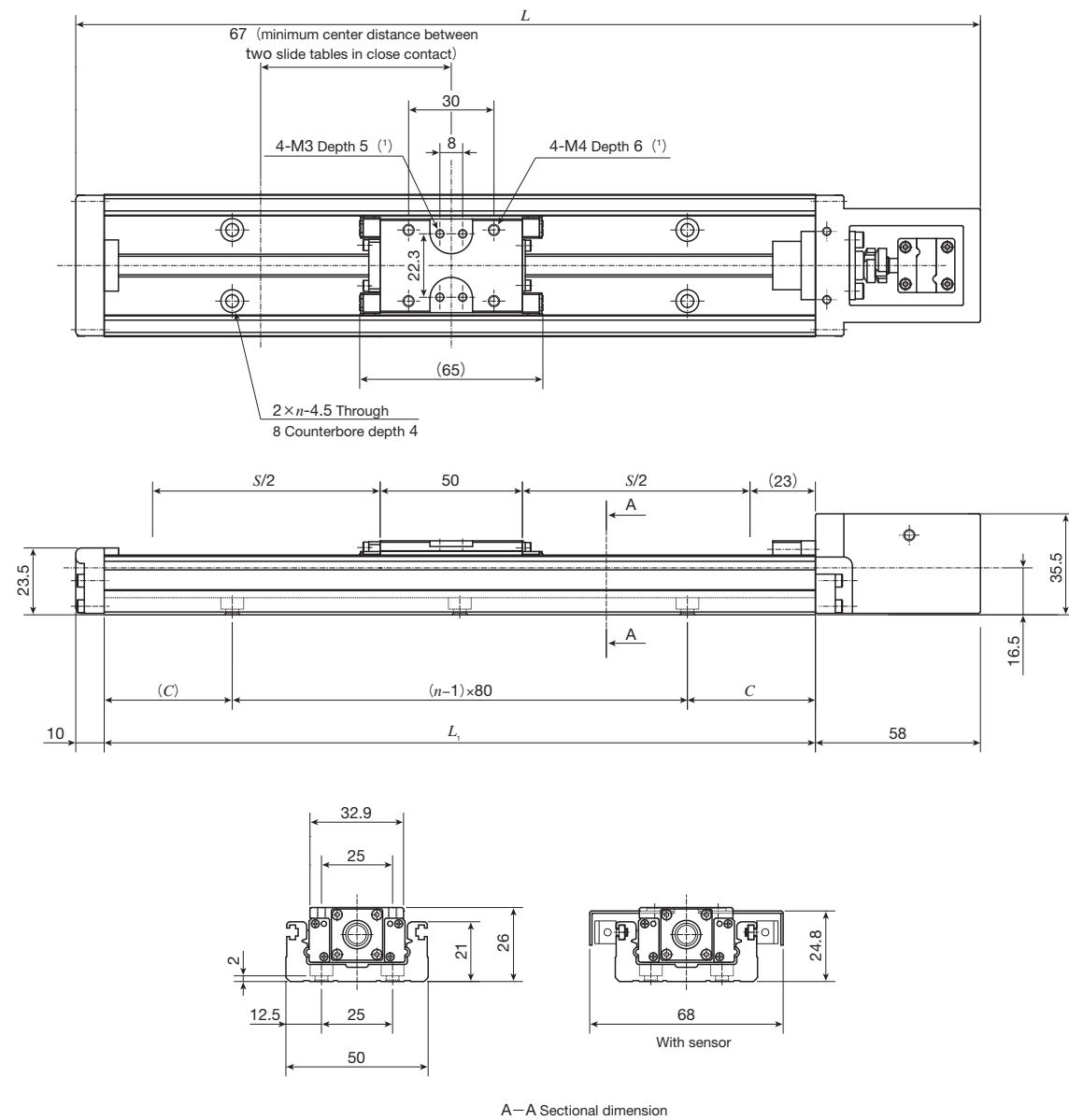

unit: mm

Bed length	Overall length	Stroke length	Mounting holes of bed		Mass (Ref.)
$L_1$	$L$	$S^{(2)}$	$C$	$n$	kg <sup>(3)</sup>
150	218	60( - )	35	2	0.52
200	268	110( 40)	20	3	0.62
250	318	160( 90)	45	3	0.72
300	368	210(140)	30	4	0.82
400	468	310(240)	40	5	1.02
500	568	410(340)	10	7	1.22

Notes (1) Too deep insertion depth of the mounting bolt may affect the running performance of the slide table, so never insert a bolt longer than the depth of the through hole.

(2) The value indicates the allowable stroke when limit sensors are mounted. The value in ( ) represents dimension for two slide tables in close contact.

(3) The value shows the mass of the entire table with one slide table, and it is 0.07kg heavier with two slide tables.

Remarks 1. Motor attachment for AC servomotor is 3.5mm lower than the bottom of the bed.

2. Motor attachment for stepper motor is 4.5mm lower than the bottom of the bed.

## TE50BF (Motor inline specification)

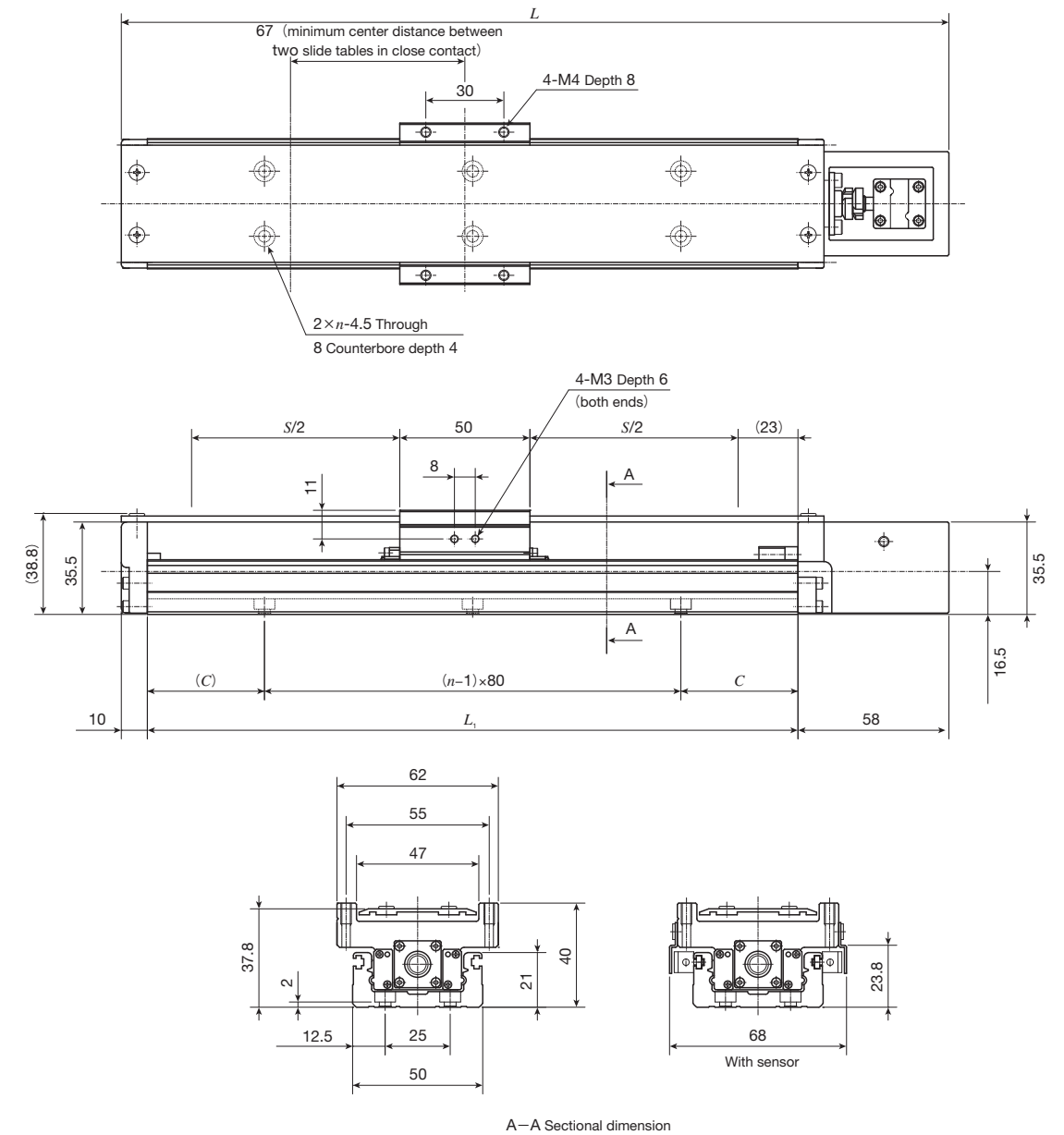

unit: mm

Bed length	Overall length	Stroke length	Mounting holes of bed		Mass (Ref.)
$L_1$	$L$	$S^{(1)}$	$C$	$n$	kg <sup>(2)</sup>
150	218	60( - )	35	2	0.65
200	268	110( 40)	20	3	0.75
250	318	160( 90)	45	3	0.85
300	368	210(140)	30	4	0.94
400	468	310(240)	40	5	1.14
500	568	410(340)	10	7	1.33

Notes (1) The value indicates the allowable stroke when limit sensors are mounted. The value in ( ) represents dimension for two slide tables in close contact.

(2) The value shows the mass of the entire table with one slide table, and it is 0.16kg heavier with two slide tables.

Remarks 1. Motor attachment for AC servomotor is 3.5mm lower than the bottom of the bed.

2. Motor attachment for stepper motor is 4.5mm lower than the bottom of the bed.

# IKO Precision Positioning Table TE

## TE60BS (Motor inline specification)

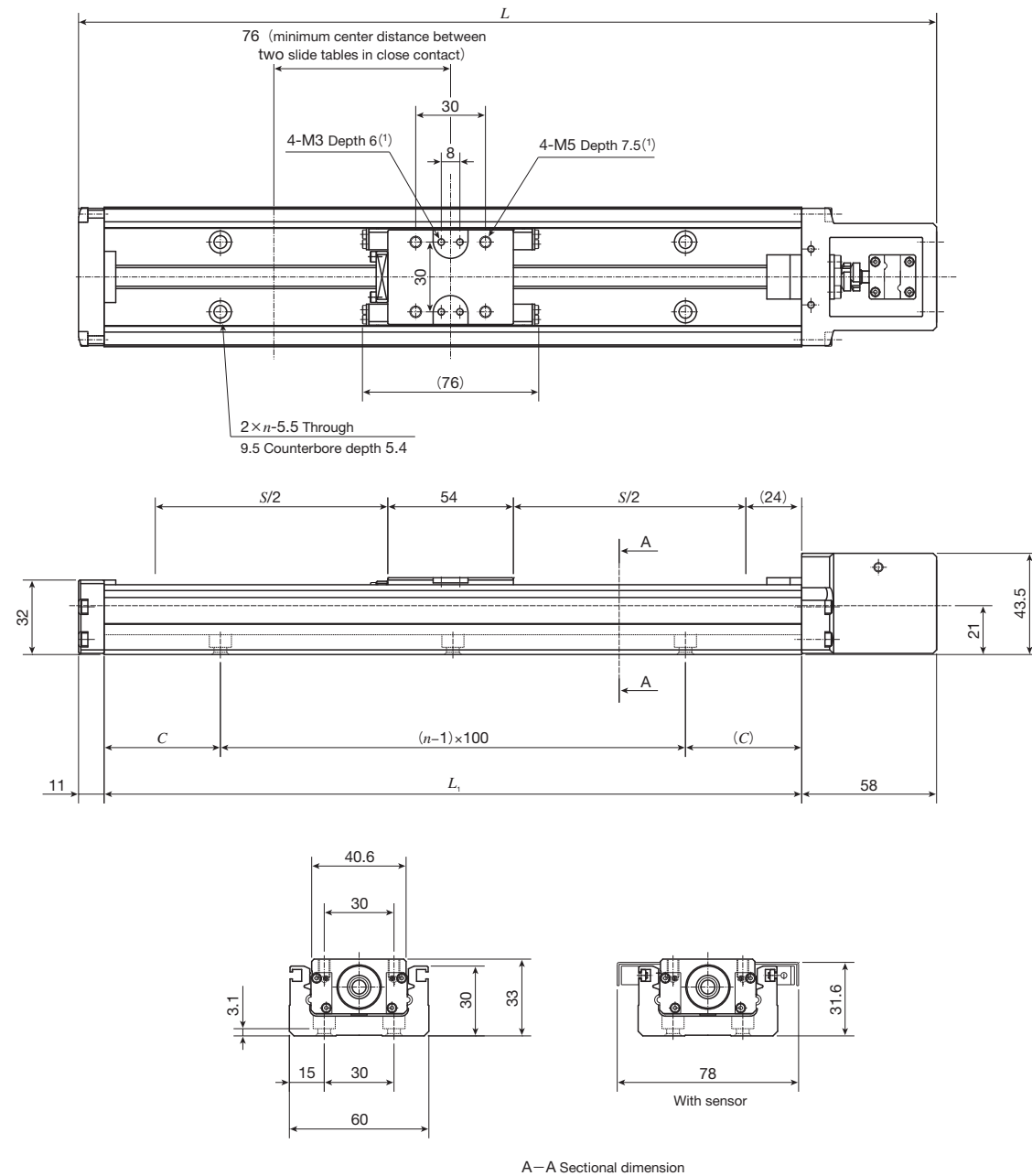

unit: mm

Bed length	Overall length	Stroke length	Mounting holes of bed		Mass (Ref.)
$L_1$	$L$	$S$ <sup>(2)</sup>	$C$	$n$	kg <sup>(3)</sup>
150	219	50( - )	25	2	0.9
200	269	100( - )	50	2	1.0
300	369	200(125)	50	3	1.3
400	469	300(225)	50	4	1.6
500	569	400(325)	50	5	1.9
600	669	500(425)	50	6	2.2
700	769	600(525)	50	7	2.5

Notes <sup>(1)</sup> Too deep a fixing thread depth of the mounting bolt may affect the running performance of the slide table, so never insert a bolt longer than the depth of the tapped hole.

<sup>(2)</sup> The value indicates the allowable stroke when limit sensors are mounted. The value in ( ) represents dimension for two slide tables in close contact.

<sup>(3)</sup> The value shows the mass of the entire table with one slide table, and it is 0.1kg heavier with two slide tables.

Remark: Motor attachment for stepper motor is 9mm lower than the bottom of the bed.

## TE60BF (Motor inline specification)

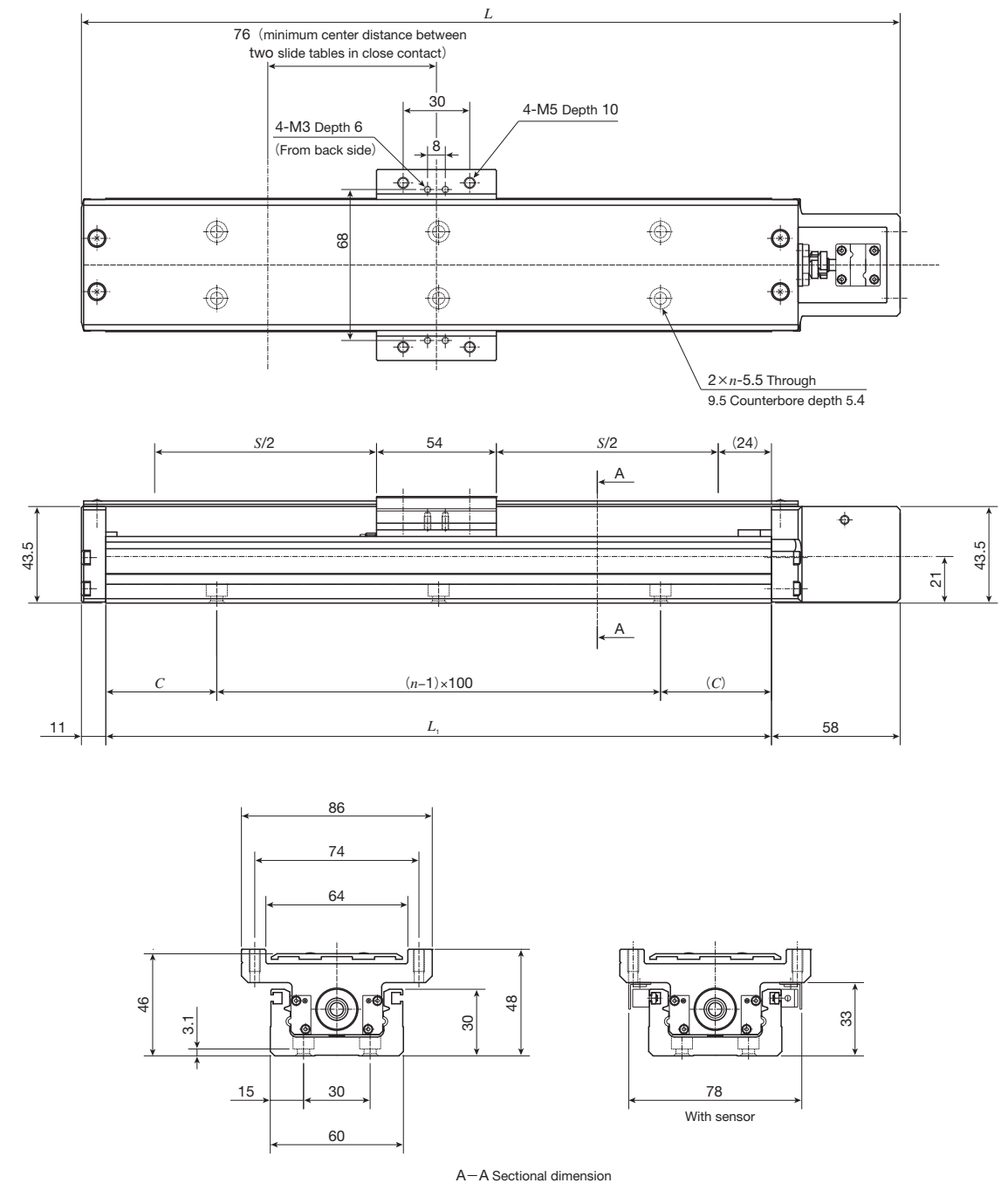

unit: mm

Bed length	Overall length	Stroke length	Mounting holes of bed		Mass (Ref.)
$L_1$	$L$	$S$ <sup>(1)</sup>	$C$	$n$	kg <sup>(2)</sup>
150	219	50( - )	25	2	1.1
200	269	100( - )	50	2	1.2
300	369	200(125)	50	3	1.5
400	469	300(225)	50	4	1.9
500	569	400(325)	50	5	2.2
600	669	500(425)	50	6	2.5
700	769	600(525)	50	7	2.8

Notes <sup>(1)</sup> The value indicates the allowable stroke when limit sensors are mounted. The value in ( ) represents dimension for two slide tables in close contact.

<sup>(2)</sup> The value shows the mass of the entire table with one slide table, and it is 0.2kg heavier with two slide tables.

Remark: Motor attachment for stepper motor is 9mm lower than the bottom of the bed.

# IKO Precision Positioning Table TE

## TE86BS (Motor inline specification)

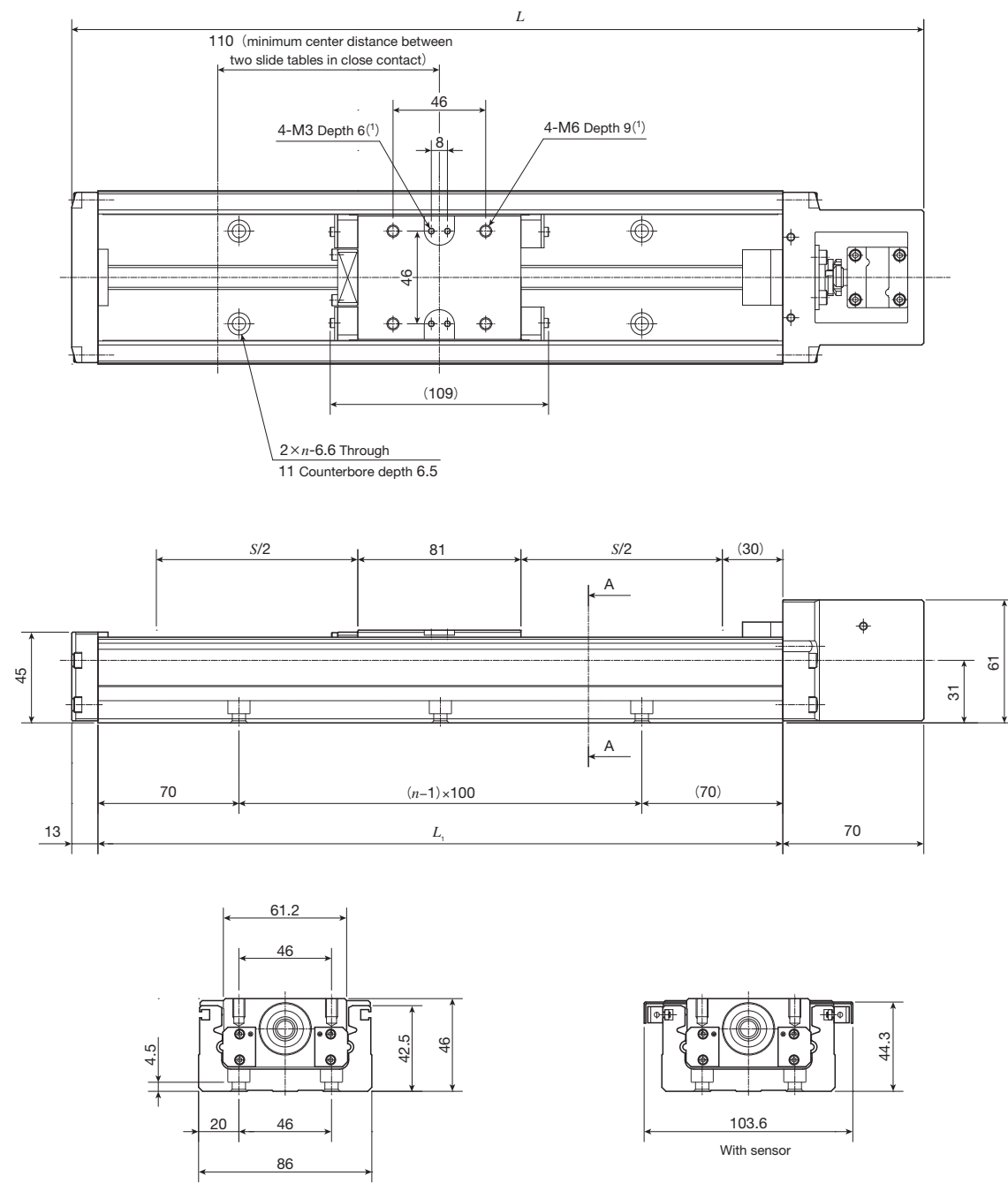

A-A Sectional dimension

unit: mm

Bed length	Overall length	Stroke length	Mounting holes of bed	Mass (Ref.)
$L_1$	$L$	$S^{(2)}$	$n$	kg <sup>(3)</sup>
340	423	200( 90)	3	3.1
440	523	300(190)	4	3.7
540	623	400(290)	5	4.2
640	723	500(390)	6	4.7
740	823	600(490)	7	5.2
840	923	700(590)	8	5.7
940	1 023	800(690)	9	6.3

Notes (1) Too deep a fixing thread depth of the mounting bolt may affect the running performance of the slide table, so never insert a bolt longer than the depth of the tapped hole.

(2) The value indicates the allowable stroke when limit sensors are mounted. The value in ( ) represents dimension for two slide tables in close contact.

(3) The value shows the mass of the entire table with one slide table, and it is 0.3kg heavier with two slide tables.

## TE86BF (Motor inline specification)

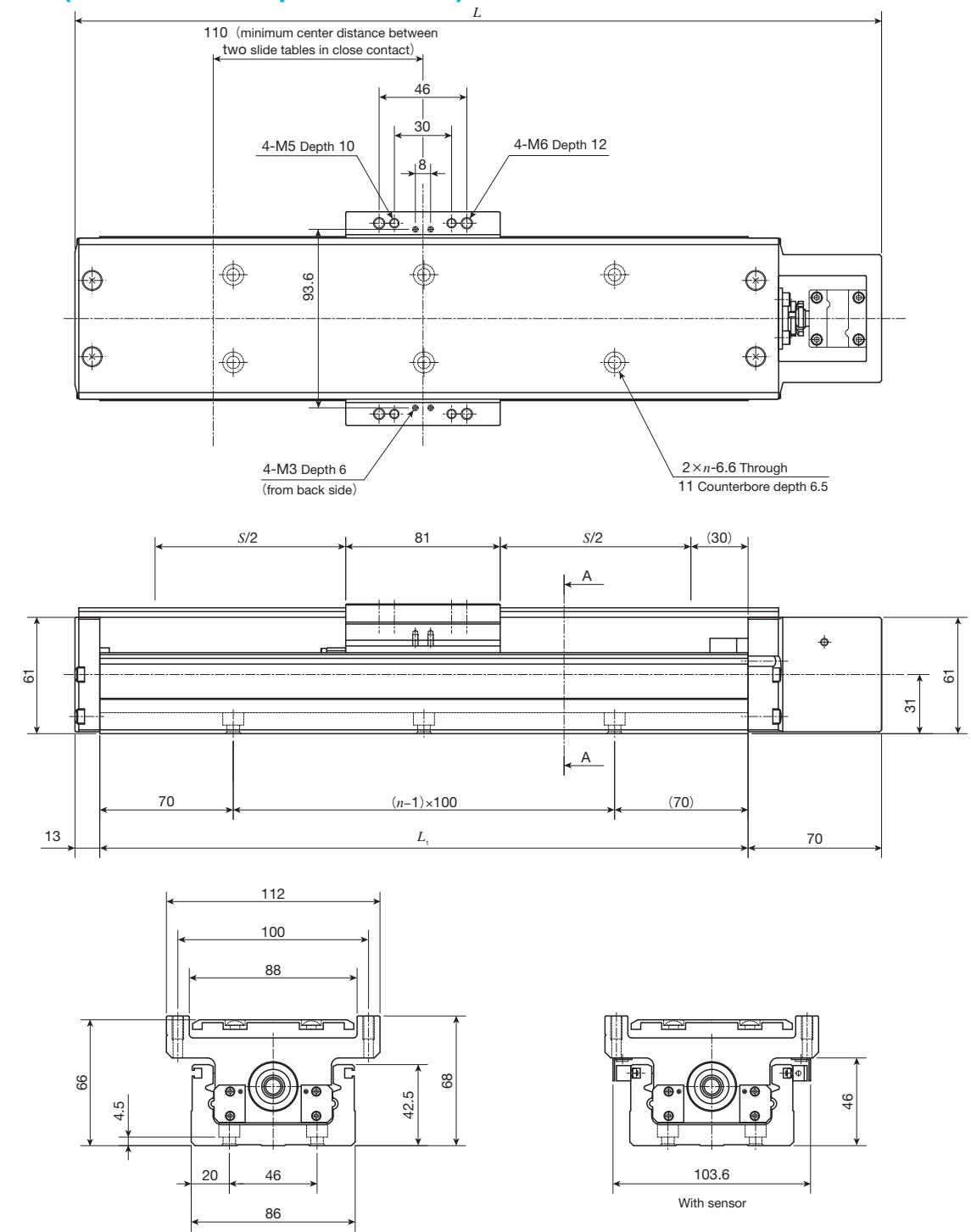

A-A Sectional dimension

unit: mm

Bed length	Overall length	Stroke length	Mounting holes of bed	Mass (Ref.)
$L_1$	$L$	$S^{(1)}$	$n$	kg <sup>(2)</sup>
340	423	200( 90)	3	3.7
440	523	300(190)	4	4.3
540	623	400(290)	5	4.9
640	723	500(390)	6	5.5
740	823	600(490)	7	6.1
840	923	700(590)	8	6.7
940	1 023	800(690)	9	7.2

Notes (1) The value indicates the allowable stroke when limit sensors are mounted. The value in ( ) represents dimension for two slide tables in close contact.

(2) The value shows the mass of the entire table with one slide table, and it is 0.6kg heavier with two slide tables.

# IKO Precision Positioning Table TE

## TE50BS (Motor folding back specification)

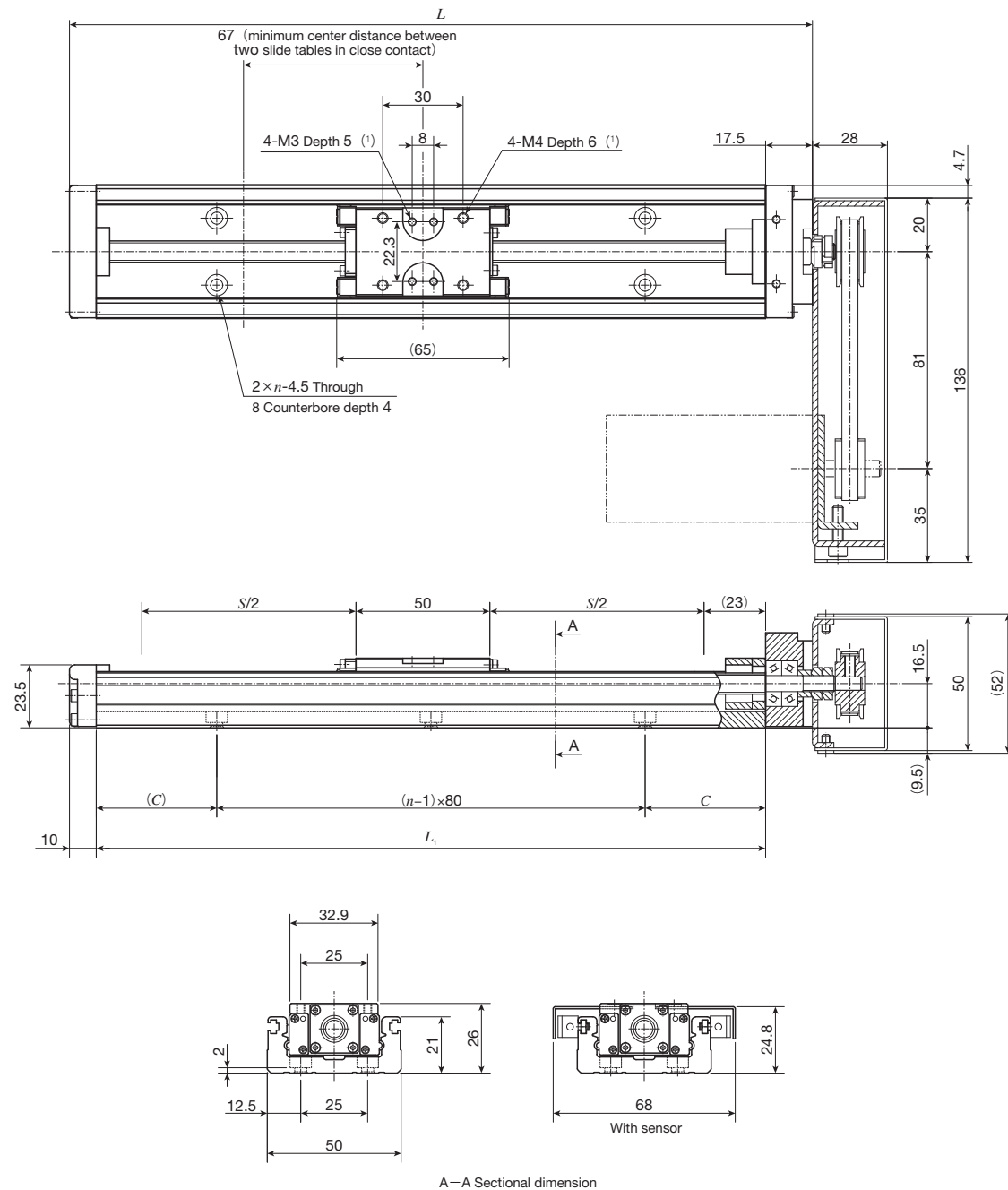

unit: mm

Bed length	Overall length	Stroke length	Mounting holes of bed		Mass (Ref.)
$L_1$	$L$	$S^{(2)}$	$C$	$n$	kg <sup>(3)</sup>
150	177.5	60( - )	35	2	0.72
200	227.5	110( 40)	20	3	0.82
250	277.5	160( 90)	45	3	0.92
300	327.5	210(140)	30	4	1.02
400	427.5	310(240)	40	5	1.22
500	527.5	410(340)	10	7	1.42

Notes <sup>(1)</sup> Too deep insertion depth of the mounting bolt may affect the running performance of the slide table, so never insert a bolt longer than the depth of the through hole.

<sup>(2)</sup> The value indicates the allowable stroke when limit sensors are mounted. The value in ( ) represents dimension for two slide tables in close contact.

<sup>(3)</sup> The value shows the mass of the entire table with one slide table, and it is 0.07kg heavier with two slide tables.

Remarks 1. Parts for motor attachment are appended, and this figure indicates a finished state after assembled by the customer.

2. If folded back to right and left, motor attachment is about 9.5mm lower than the bottom of the bed. In addition, it is about 2.5 to 3.5mm lower than the bottom of the bed if AC servomotor is mounted by customers, and about 4.5mm lower if stepper motor is mounted.

3. If folded back upward, motor attachment is about 3.5mm lower than the bottom of the bed.

## TE50BF (Motor folding back specification)

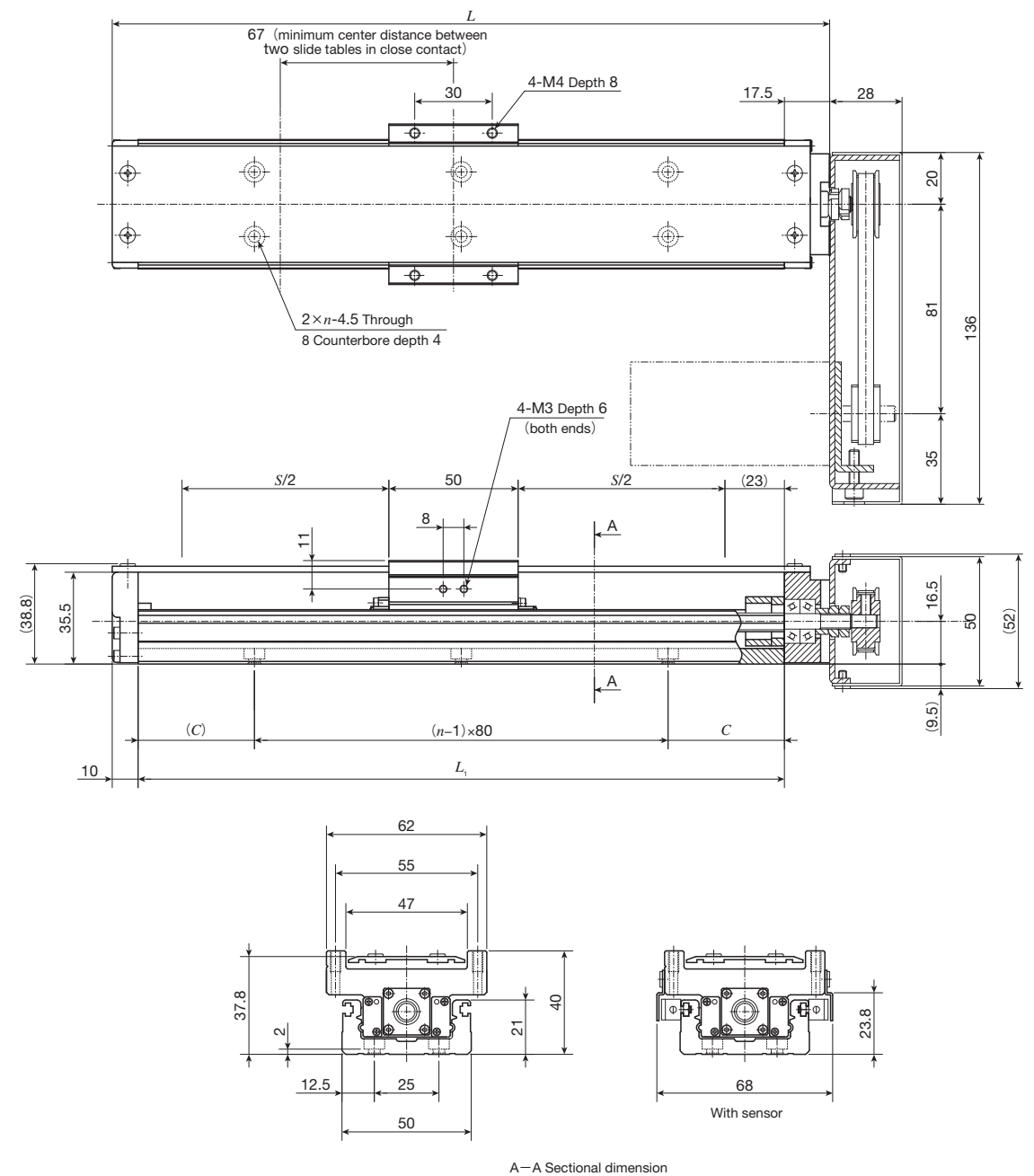

unit: mm

Bed length	Overall length	Stroke length	Mounting holes of bed		Mass (Ref.)
$L_1$	$L$	$S^{(1)}$	$C$	$n$	kg <sup>(2)</sup>
150	177.5	60( - )	35	2	0.85
200	227.5	110( 40)	20	3	0.95
250	277.5	160( 90)	45	3	1.05
300	327.5	210(140)	30	4	1.15
400	427.5	310(240)	40	5	1.35
500	527.5	410(340)	10	7	1.55

Notes <sup>(1)</sup> The value indicates the allowable stroke when limit sensors are mounted. The value in ( ) represents dimension for two slide tables in close contact.

<sup>(2)</sup> The value shows the mass of the entire table with one slide table, and it is 0.16kg heavier with two slide tables.

Remarks 1. Parts for motor attachment are appended, and this figure indicates a finished state after assembled by the customer.

2. If folded back to right and left, motor attachment is about 9.5mm lower than the bottom of the bed. In addition, it is about 2.5 to 3.5mm lower than the bottom of the bed if AC servomotor is mounted by customers, and about 4.5mm lower if stepper motor is mounted.

3. If folded back upward, motor attachment is about 3.5mm lower than the bottom of the bed.



# IKO Precision Positioning Table TE

## TE60BS (Motor folding back specification)

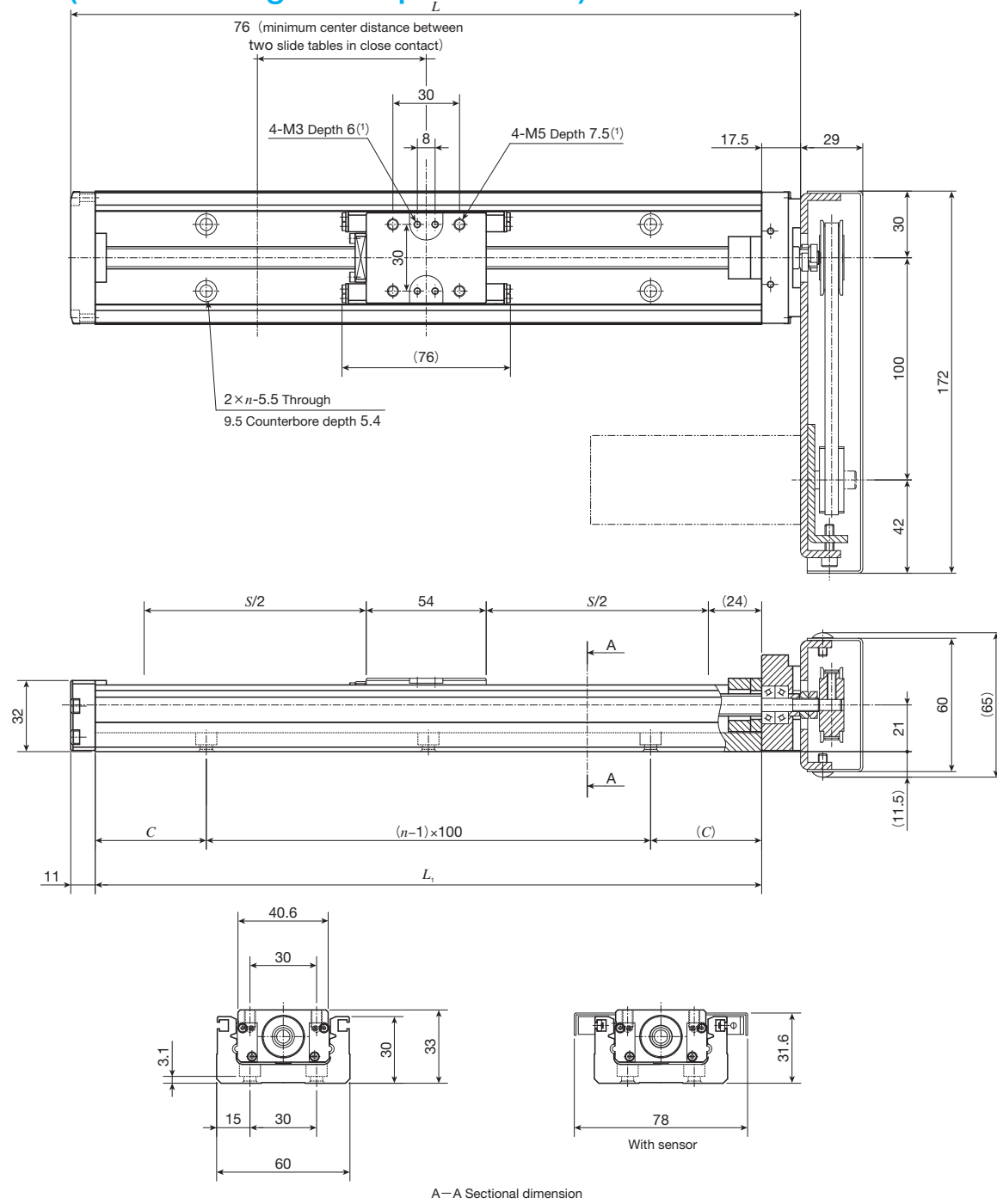

A-A Sectional dimension

unit: mm

Bed length	Overall length	Stroke length	Mounting holes of bed		Mass (Ref.)
$L_1$	$L$	$S^{(2)}$	$C$	$n$	kg <sup>(3)</sup>
150	178.5	50( - )	25	2	1.2
200	228.5	100( - )	50	2	1.3
300	328.5	200(125)	50	3	1.6
400	428.5	300(225)	50	4	1.9
500	528.5	400(325)	50	5	2.2
600	628.5	500(425)	50	6	2.5
700	728.5	600(525)	50	7	2.8

Notes <sup>(1)</sup> Too deep a fixing thread depth of the mounting bolt may affect the running performance of the slide table, so never insert a bolt longer than the depth of the tapped hole.

<sup>(2)</sup> The value indicates the allowable stroke when limit sensors are mounted. The value in ( ) represents dimension for two slide tables in close contact.

<sup>(3)</sup> The value shows the mass of the entire table with one slide table, and it is 0.1kg heavier with two slide tables.

Remarks 1. Parts for motor attachment are appended, and this figure indicates a finished state after assembled by the customer.

2. If folded back to right and left, motor attachment is about 11.5mm lower than the bottom of the bed.

3. If folded back upward, motor attachment is about 9mm lower than the bottom of the bed.

## TE60BF (Motor folding back specification)

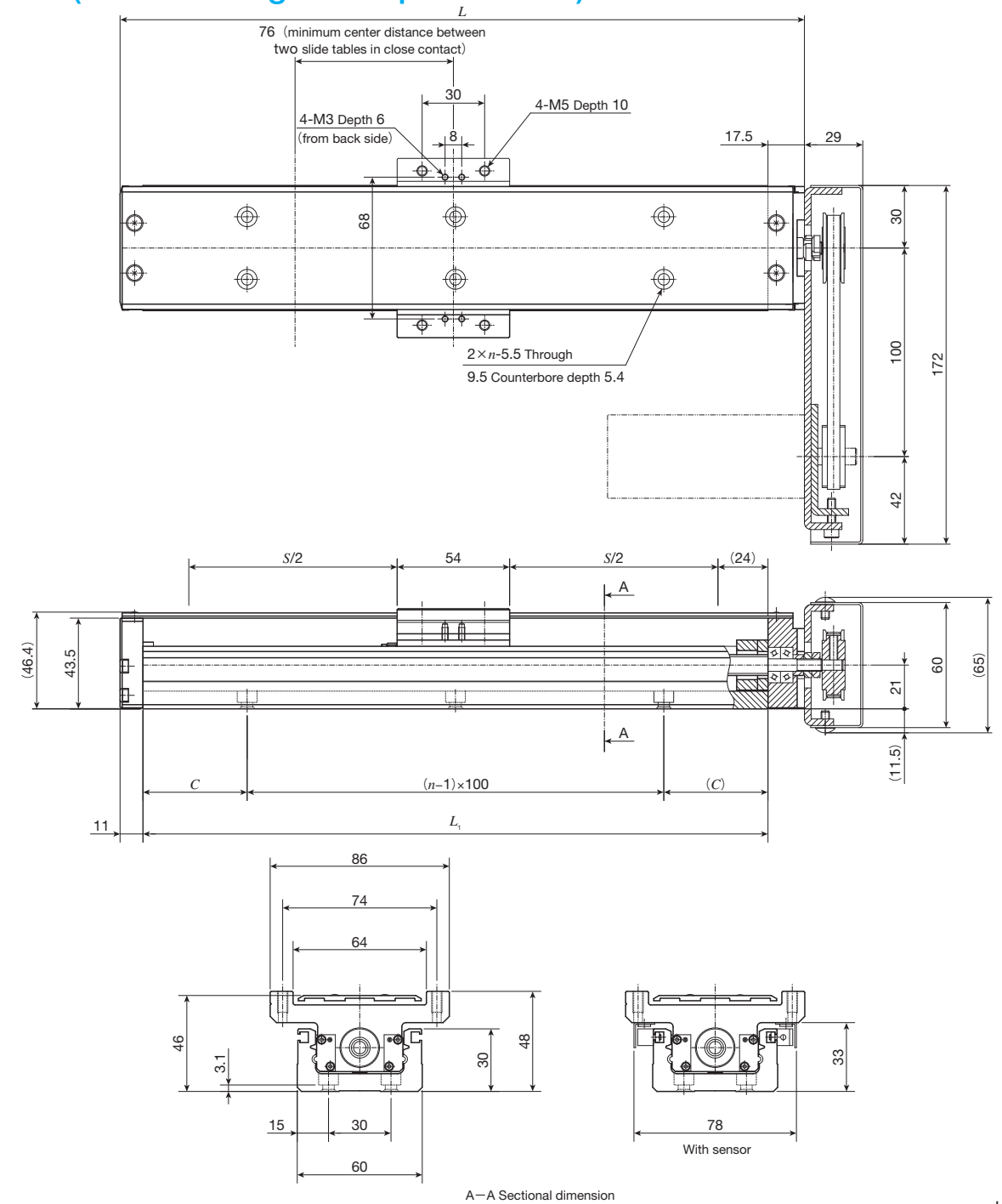

A-A Sectional dimension

unit: mm

Bed length	Overall length	Stroke length	Mounting holes of bed		Mass (Ref.)
$L_1$	$L$	$S^{(1)}$	$C$	$n$	kg <sup>(2)</sup>
150	178.5	50( - )	25	2	1.4
200	228.5	100( - )	50	2	1.5
300	328.5	200(125)	50	3	1.8
400	428.5	300(225)	50	4	2.2
500	528.5	400(325)	50	5	2.5
600	628.5	500(425)	50	6	2.8
700	728.5	600(525)	50	7	3.1

Notes <sup>(1)</sup> The value indicates the allowable stroke when limit sensors are mounted. The value in ( ) represents dimension for two slide tables in close contact.

<sup>(2)</sup> The value shows the mass of the entire table with one slide table, and it is 0.2kg heavier with two slide tables.

Remarks 1. Parts for motor attachment are appended, and this figure indicates a finished state after assembled by the customer.

2. If folded back to right and left, motor attachment is about 11.5mm lower than the bottom of the bed.

3. If folded back upward, motor attachment is about 9mm lower than the bottom of the bed.

# IKO Precision Positioning Table TE

## TE86BS (Motor folding back specification)

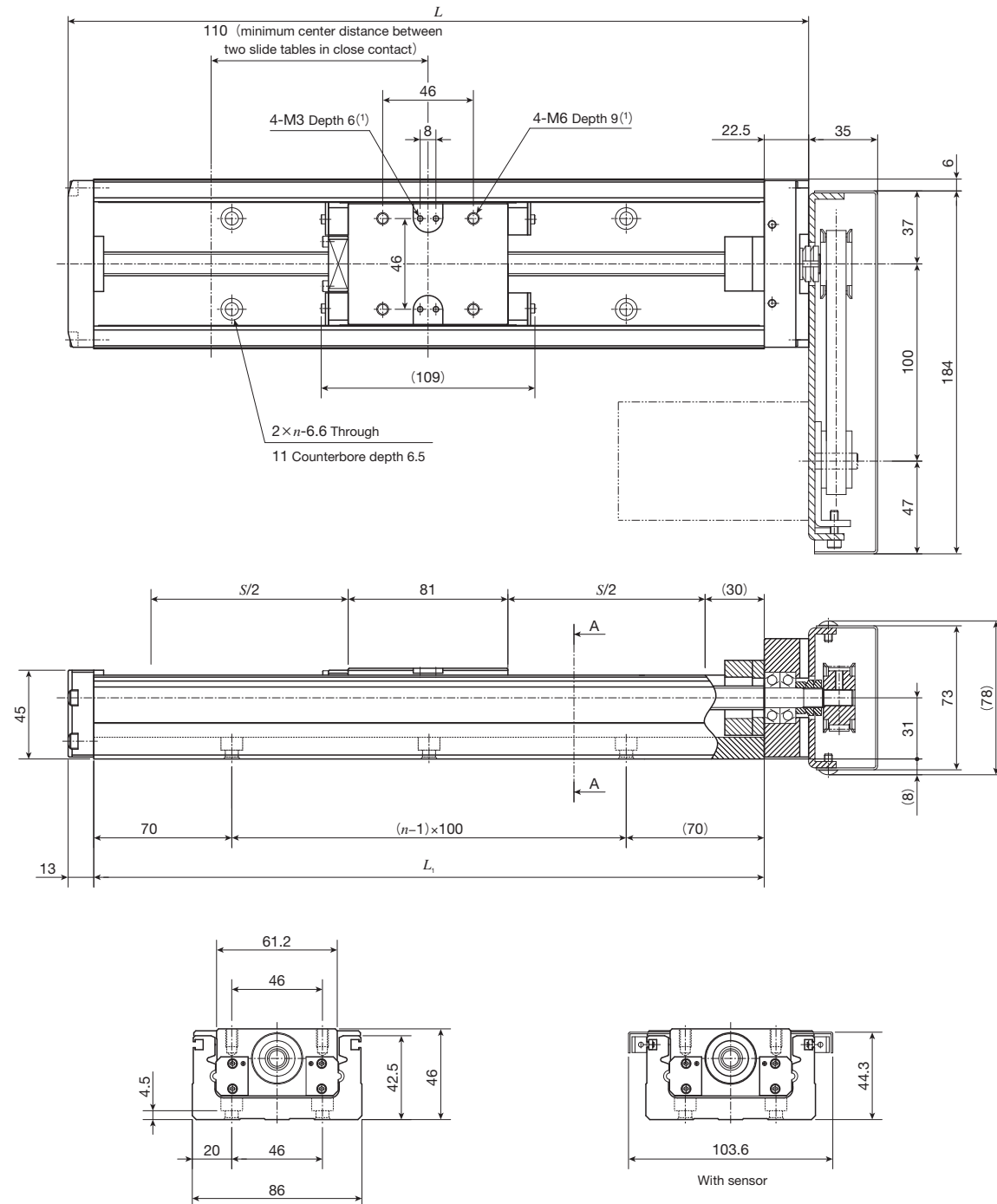

A-A Sectional dimension unit: mm

Bed length $L_1$	Overall length $L$	Stroke length $S^{(2)}$	Mounting holes of bed $n$	Mass (Ref.) kg <sup>(3)</sup>
340	375.5	200( 90)	3	4.0
440	475.5	300(190)	4	4.6
540	575.5	400(290)	5	5.1
640	675.5	500(390)	6	5.6
740	775.5	600(490)	7	6.1
840	875.5	700(590)	8	6.6
940	975.5	800(690)	9	7.2

Notes <sup>(1)</sup> Too deep a fixing thread depth of the mounting bolt may affect the running performance of the slide table, so never insert a bolt longer than the depth of the tapped hole.

<sup>(2)</sup> The value indicates the allowable stroke when limit sensors are mounted. The value in ( ) represents dimension for two slide tables in close contact.

<sup>(3)</sup> The value shows the mass of the entire table with one slide table, and it is 0.3kg heavier with two slide tables.

Remarks 1. Parts for motor attachment are appended, and this figure indicates a finished state after assembled by the customer.

2. If folded back to right and left, motor attachment is about 8mm lower than the bottom of the bed.

3. If folded back upward, motor attachment is about 6mm lower than the bottom of the bed.

## TE86BF (Motor folding back specification)

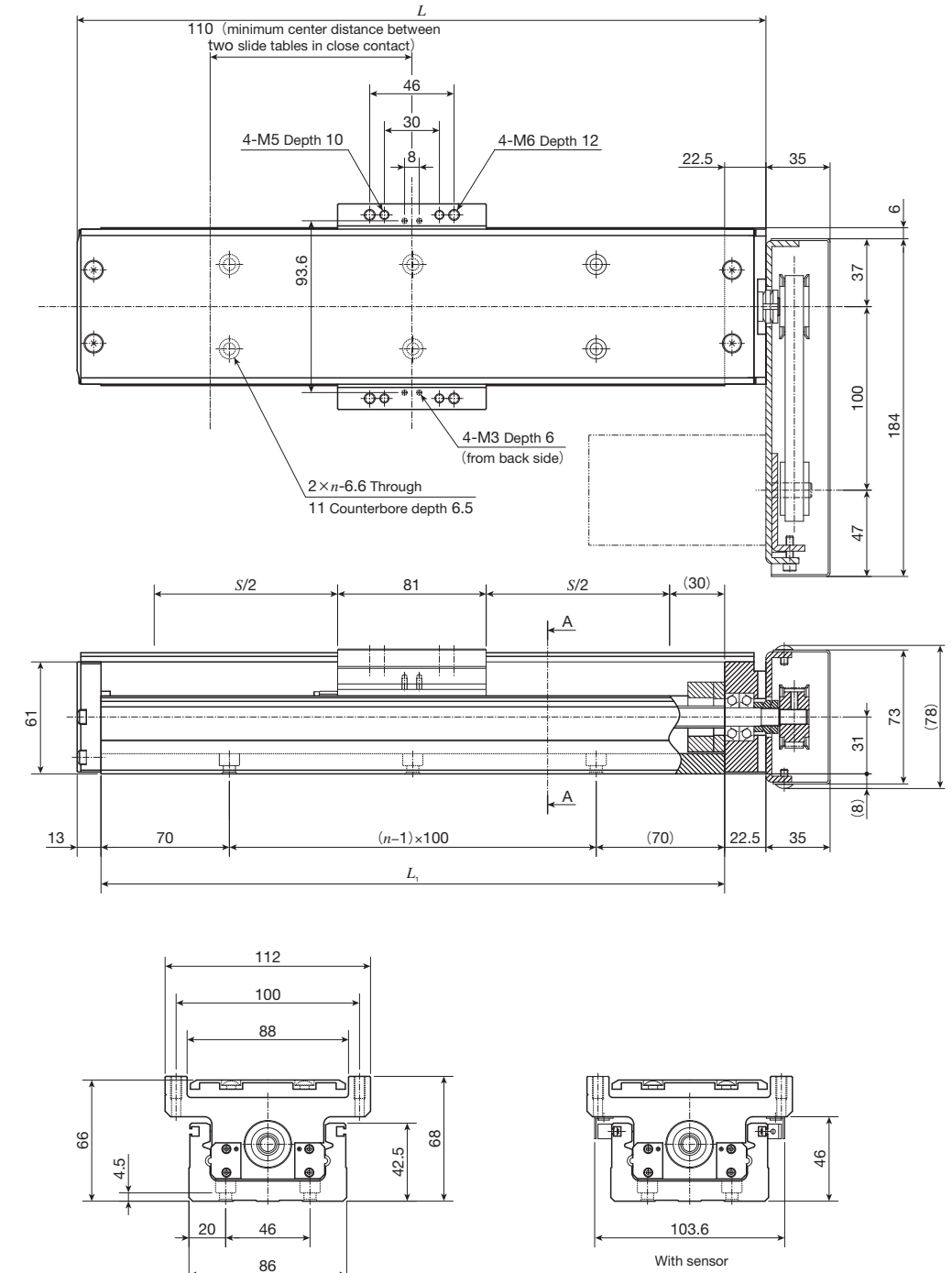

A-A Sectional dimension unit: mm

Bed length $L_1$	Overall length $L$	Stroke length $S^{(1)}$	Mounting holes of bed $n$	Mass (Ref.) kg <sup>(2)</sup>
340	375.5	200( 90)	3	4.6
440	475.5	300(190)	4	5.2
540	575.5	400(290)	5	5.8
640	675.5	500(390)	6	6.4
740	775.5	600(490)	7	7.0
840	875.5	700(590)	8	7.6
940	975.5	800(690)	9	8.1

Notes <sup>(1)</sup> The value indicates the allowable stroke when limit sensors are mounted. The value in ( ) represents dimension for two slide tables in close contact.

<sup>(2)</sup> The value shows the mass of the entire table with one slide table, and it is 0.6kg heavier with two slide tables.

Remarks 1. Parts for motor attachment are appended, and this figure indicates a finished state after assembled by the customer.

2. If folded back to right and left, motor attachment is about 8mm lower than the bottom of the bed.

3. If folded back upward, motor attachment is about 6mm lower than the bottom of the bed.